

Exploded Drawing

GT887 A

C-80-0000000

Organization :

To examine :

Approval :

Version: A-02

2012.12.27

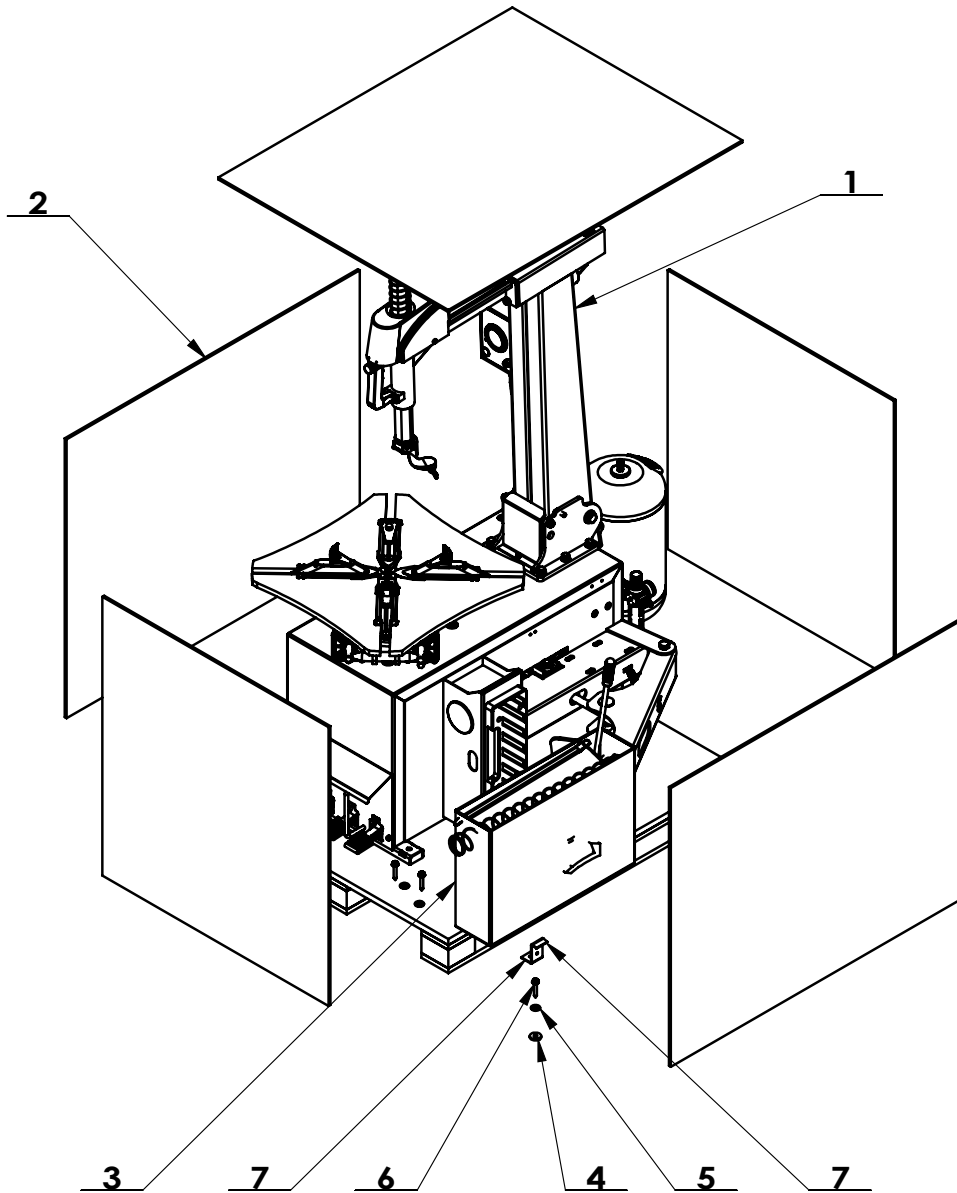

ITEM	PART. No	DESCRIPTION.	QT. Y
1	C-80-1000000	887 ITA	1
2	C-80-9100000	PACKAGE	1
3	C-80-8000000	ACCESSORY BOX	1
4	C-70-9000003	PACKAGE SPACER	4
5	GB96. 2-8	LARGE WASHER C GRADE	6
6	GB16824. 1-ST8×50 C	HEXA FLANGE TAPPING SCREW	6
7	C-80-1000010	PRESSURE CHECK	1

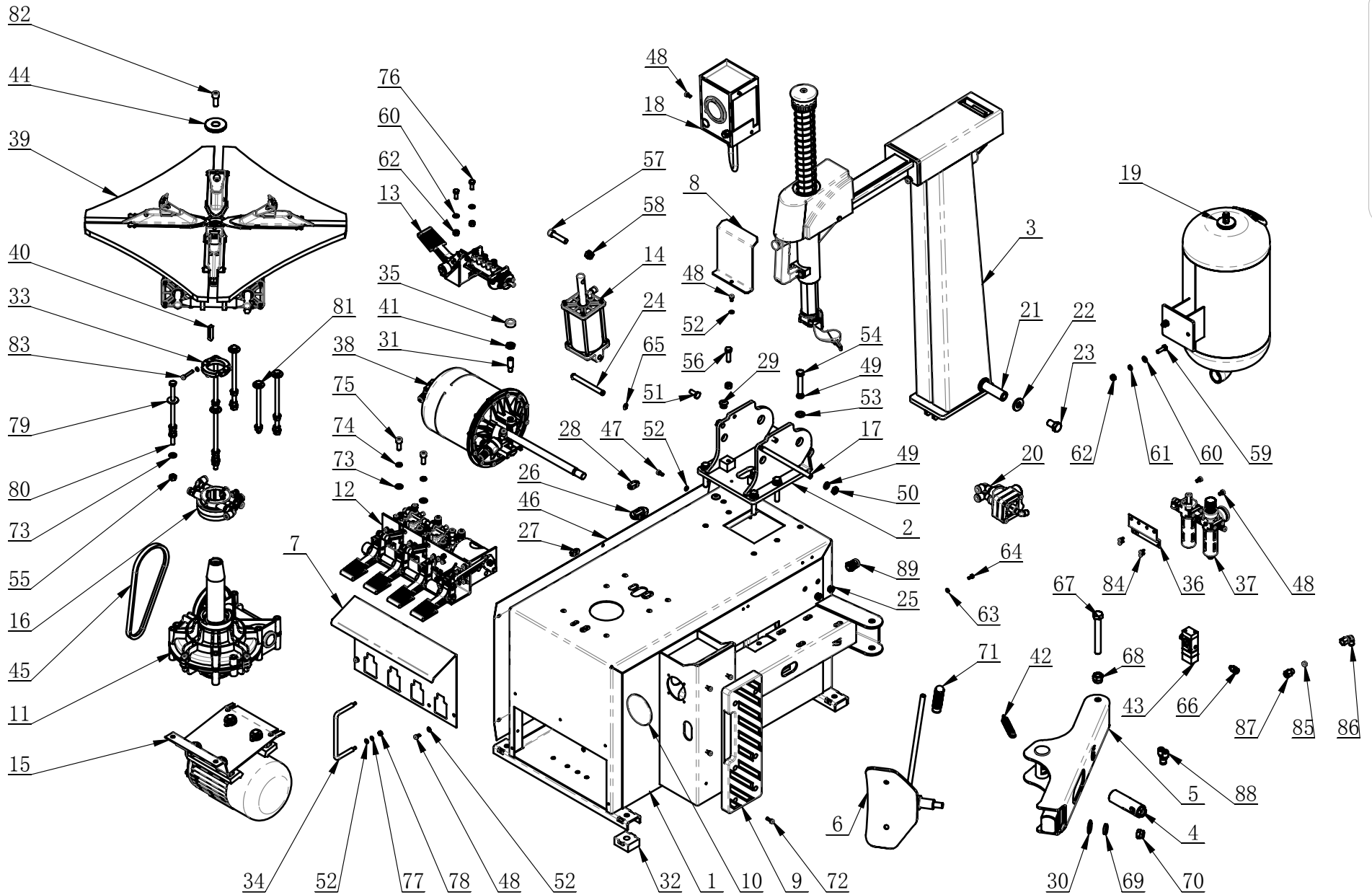

ITEM	PART. No	DESCRIPTION.	QT. Y
1	C-80-1100000	BODY WELDING	1
2	C-80-1200000	ATTENDANCE	1
3	C-80-1300000	HORIZONTAL ARM	1
4	C-80-1400000	ADJUSTING SLEEVE	1
5	CT-B-9000000	BEAD BREAKER	1
6	CT-C-2100000	BEAD BREAKER BLADE	1
7	C-7C-1000001	PROTECTIVE COVER	1
8	C-80-1000002	GUARD BOARD	1
9	C-80-1000003	RUBBER PAD PLATE	1
10	C-80-1000004	RUBBER PLUG	1
11	CT-J-4100000	GEARBOX ASSEMBLY	1
12	CT-D-4600000	PEDAL ASSEMBLY	1
13	CT-K-1300000	QUICK INFLATION PEDAL ASSY	1
14	CT-XD-1000000	PULL-OUT CYLINDER D80X80	1
15	CT-DJ-0218112	MOTOR ASSEMBLY	1
16	CT-Q-4000000	AIR GUIDER	1
17	C-80-1000007	ROTATION SHAFT	1
18	CT-K-3500000	INFLATOR COVER ASSEMBLY	1
19	CT-K-4100000	AIR TANK	1
20	CT-K-2200000	QUICK EXHAUST VALVE ASSY	1
21	C-80-1000008	ROTATION SHAFT	1
22	C-70-1000008	WASHER	2
23	C-80-1000009	HEXANGULAR BOLT	2
24	C-70-1000004	PIN SHAFT	1
25	C-70-1000006	φ 12 RUBBER PLUG	2
26	C-90-1000002	PLUG B	1
27	C-90-1000003	PLUG A	2
28	C-90-1000004	PLUG C	2
29	C-70-1000014	STOP-UP	2
30	CT-C-2100003	WASHER	1
31	C-70-1000021	INNER HEXA CYLINDRICAL TERMINUS SET SCREW	2
32	C-54-1000005	RUBBER FOOT	4
33	CT-Q-0000001	CLAMP RING	2
34	C-90-1000012	PROTECTIVE ROD	1
35	C-70-1000011	SEALED COVER	1
36	C-90-1000013	AIR REGULATOR BRACKET	1
37	CT-F-2122111	AIR REGULATOR ASSEMBLY	1
38	CT-LS-7400000	BEAD BREAKER CYLINDER ASSEMBLY	1
39	CT-Y-5700000	TURNTABLE ASSEMBLY	1
40	GB1096-C12×8×45	COMMON FLAT KEY	1
41	GB6172. - M14	HEXANGULAR THIN NUT	2
42	CT-B-2000002	SPRING	1
43	CH-34-1000001	PRESSURE LIMIT VALVE	1
44	CT-Y-0100001	PRESS COVER	1
45	CT-DJ-0000007	BELT A-25	1

ITEM	PART. No	DESCRIPTION.	QT. Y
46	C-80-1000001	SIDE PANEL	1
47	GB70. 1-M6×12	INNER HEXA CYLINDRICAL SCREW	5
48	GB70. 1-M6×10	INNER HEXA CYLINDRICAL SCREW	10
49	GB93-12	STANDARD SPRING WASHER	8
50	GB6172. 1-M12	HEXANGULAR THIN NUT	2
51	C-70-1000005	BOLT	2
52	GB95-6	FLAT WASHER	13
53	GB95-12	FLAT WASHER	6
54	GB5782-M12×65	HEXANGULAR BOLT	6
55	GB41-M10	HEXANGULAR NUT	16
56	GB5781-M10×35	HEXANGULAR BOLT	2
57	GB70. 1-M12×50	INNER HEXA CYLINDRICAL SCREW	1
58	GB889. 1-M12	1-TYPE PREVAILING TORQUE TYPE HEXAGON LOCK NUT	1
59	GB/T 5781-2000 - M8×25	HEXANGULAR BOLT	2
60	GB95-8	FLAT WASHER	4
61	GB93-8	STANDARD SPRING WASHER	4
62	GB41-M8	HEXANGULAR NUT	4
63	GB95-5	FLAT WASHER	2
64	GB5781-M5×12	HEXANGULAR BOLT	1
65	GB894. 1-12	SHAFT ELATIC BIG RETAINING RING A-TYPE	2
66	FPC 8-01	MALE STRAIGHT	2
67	GB5782-M16×120	HEXANGULAR BOLT	1
68	GB889. 1-M16	1-TYPE PREVAILING TORQUE TYPE HEXAGON LOCK NUT	1
69	GB955-14	WAVE-FORM SPRING WASHER	1
70	GB889. 1-M14	1-TYPE PREVAILING TORQUE TYPE HEXAGON LOCK NUT	1
71	C-54-1300011	RUBBER COVER	1
72	GB70. 1-M6×16	INNER HEXA CYLINDRICAL SCREW	6
73	GB95-10	FLAT WASHER	16
74	GB93-10	STANDARD SPRING WASHER	2
75	GB70. 1-M10×25	INNER HEXA CYLINDRICAL SCREW	2
76	GB5783-M8×20	HEXANGULAR BOLT	2
77	GB93-6	STANDARD SPRING WASHER	5
78	GB41-M6	HEXANGULAR NUT	2
79	GB96. 1-10	LARGE WASHER A GRADE	6
80	GB5781-M10X200	BOLT M10X200	4
81	GB/5781-M10×160	HEXANGULAR BOLT	2
82	GB70. 1-M12×30	INNER HEXA CYLINDRICAL SCREW	1
83	GB70. 1-M6×35	INNER HEXA CYLINDRICAL SCREW	2
84	GB70. 1-M4×10	INNER HEXA CYLINDRICAL SCREW	4
85	C-70-1000018	JOINT SEALING GASKET	2
86	FPLF 8-02	FEMALE ELBOW	2
87	FPC 8-02	MALE STRAIGHT	2
88	FPY-8	UNION Y	2
89	C-01-1000004	CABLE CONNECTOR	1

C-80-1300000

REVISION A-01

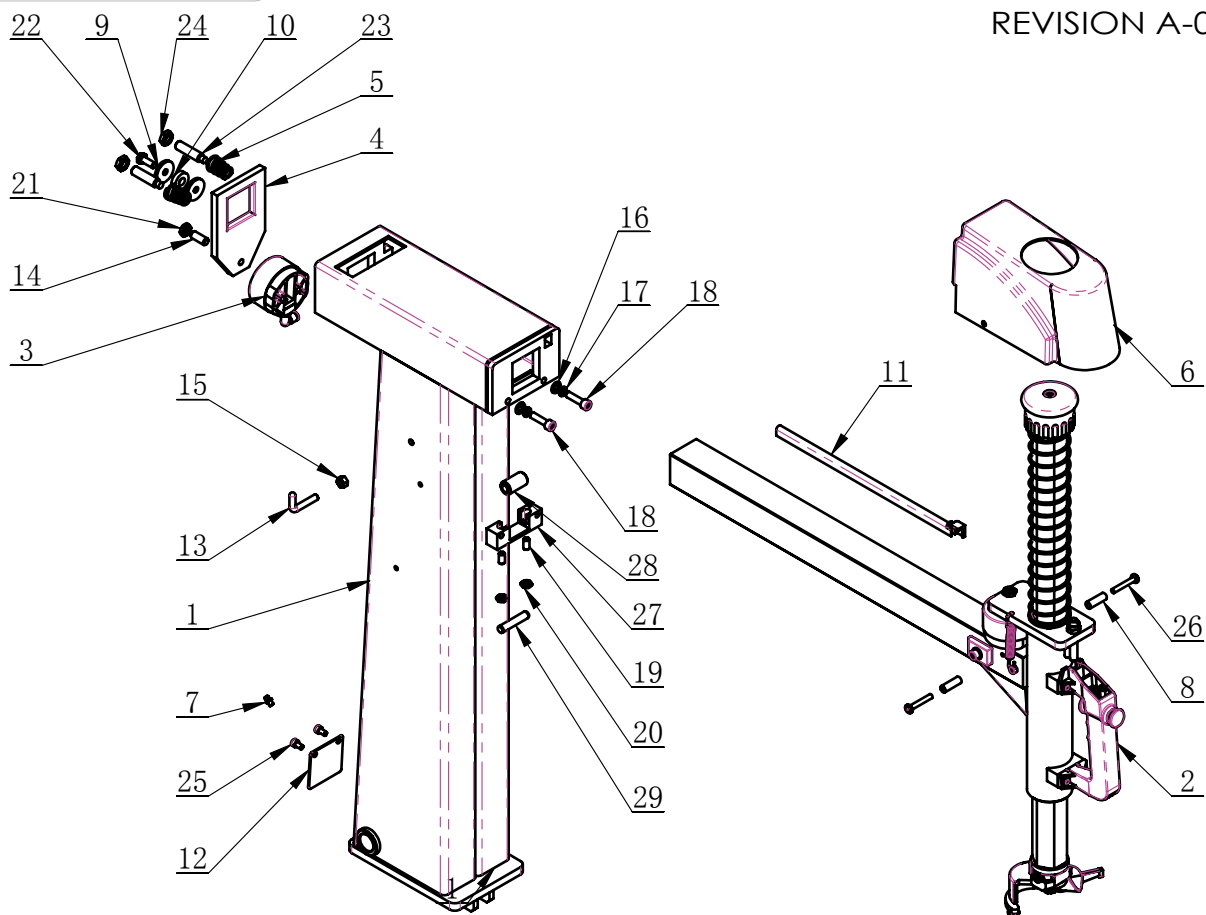

ITEM	PART. No		DESCRIPTION.	QT. Y
1	C-80-1310000		COLUMN WELDING DRAWING	1
2	C-80-1320000		HORIZONTAL ARM	1
3	C-80-1330000		LOCKING CYLINDER ASSY	1
4	C-80-1300001		SQUARE LOCK PLATE	1
5	C-80-1300002		PRESS SPRING	2
6	C-80-1300006		PROTECTION COVER	1
7	BZJYB		OIL CUP	1
8	C-90-1200005		PROTECTIVE HOOD LOCK BUSHING	2
9	C-90-1200006		CUSHION	2
10	C-90-1200007		RUBBER WASHER	1
11	C-90-1200008		AIR HOSE CHUTE	1
12	C-90-1200013		BLOCK PLATE	1
13	C-60-1000002		INFLATING GUN HOOK	1
14	C-70-1200010		INNER HEXA FLAT TERMINUS SET SCREW	1
15	GB41-M8		HEXANGULAR NUT	1
16	GB95-8		FLAT WASHER	2
17	GB93-8		STANDARD SPRING WASHER	2
18	GB70. 1-M8×30		INNER HEXA CYLINDRICAL SCREW	2
19	GB77-M8×16		INNER HEXA FLAT TERMINUS SET SCREW	2
20	GB6172. 1-M8		HEXANGULAR THIN NUT	2
21	GB6173-M10×1. 0		HEXA THIN NUT	1
22	GB5781- M8×20		HEXANGULAR BOLT	1
23	GB79-M12×50		INNER HEXA CYLINDRICAL TERMINUS SET SCREW	2
24	GB6172. 1-M12		HEXANGULAR THIN NUT	2
25	GB70. 1-M6×10		INNER HEXA CYLINDRICAL SCREW	2
26	GB818-M6×40-H		CROSS PANHEAD SCREW	2
27	C-80-1300003		TELEFLEX BASE	1
28	C-80-1300004		TELEFLEX	1
29	GB119. 2-10×50		CYLINDRICAL PIN	1

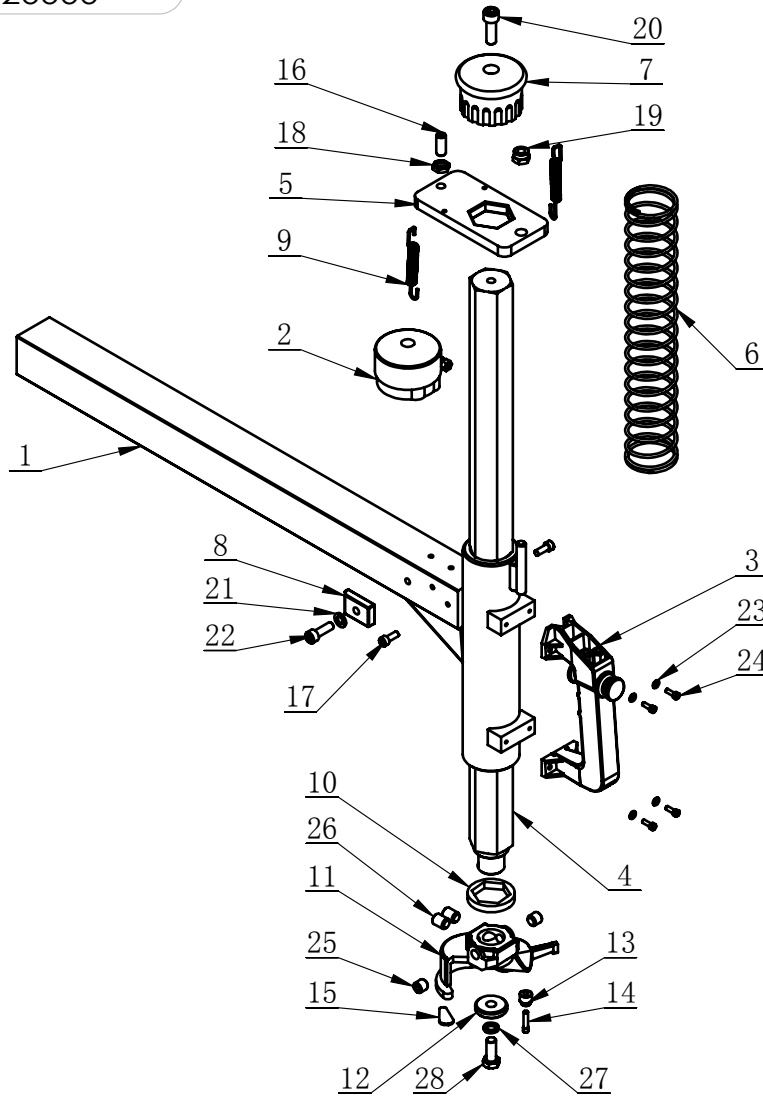

ITEM	PART. No	DESCRIPTION.	QT. Y
1	C-80-1321000	HORIZONTAL ARM WELDING	1
2	C-70-1223000	LOCKING CYLINDER ASSY	1
3	C-70-1224000	HANDLE CONTROLLING VALVE	1
4	C-80-1320001	HEXAGON SHAFT	1
5	C-80-1320002	HEXANGULAR LOCK PLATE	1
6	C-80-1320003	VERTICAL SHAFT SPRING	1
7	C-90-1220004	VERTICAL SHAFT COVER	1
8	C-70-1220005	POSITIONING BLOCK	1
9	C-70-1220004	SPRING	2
10	C-54-1300007	SHOCK ABSORBER WASHER	1
11	C-31-1300013	DEMOUNTING HEAD	1
12	C-54-1300008	PRESS WASHER	1
13	C-54-1300009	ROLLER	1
14	C-54-1300006	ROLLER BOLT	1
15	C-31-1300015	PLASTIC COVER	1
16	C-70-1200010	INNER HEXA FLAT TERMINUS SET SCREW	1
17	GB70. 1-M6×16	INNER HEXA CYLINDRICAL SCREW	2
18	GB6173-M10×1.0	HEXA THIN NUT	1
19	GB889. 1- M10	1-TYPE PREVAILING TORQUE TYPE HEXAGON LOCK NUT	1
20	GB70. 1-M10×30	INNER HEXA CYLINDRICAL SCREW	1
21	GB95-8	FLAT WASHER	1
22	GB70. 1-M8×25	INNER HEXA CYLINDRICAL SCREW	1
23	GB95-4	FLAT WASHER	4
24	GB70. 1-M4×12	INNER HEXA CYLINDRICAL SCREW	4
25	GB77-M12×12	INNER HEXA FLAT TERMINUS SET SCREW	2
26	GB77-M12×16	INNER HEXA FLAT TERMINUS SET SCREW	2
27	GB93-10	STANDARD SPRING WASHER	1
28	GB5783-M10×25	HEXANGULAR BOLT	1

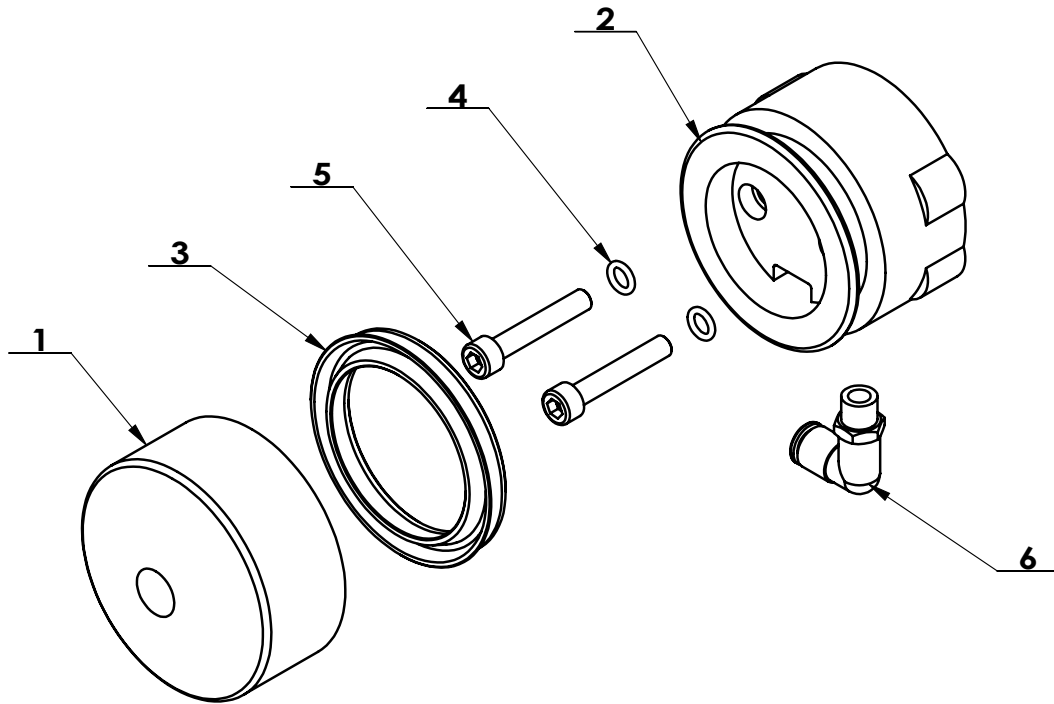

ITEM	PART. No	DESCRIPTION.	QT. Y
1	C-70-1223001	LOCK TURNTABLE CYLINDER HEAD	1
2	C-70-1223002	LOCK TURNTABLE CYLINDER HOUSING	1
3	C-70-1223003	Y-RING	1
4	GB3452. 1-6×1.8-G	O-RING G TYPE	2
5	GB70. 1-M6×35	INNER HEXA CYLINDRICAL SCREW	2
6	FPL 6-01	MALE ELBOW	1

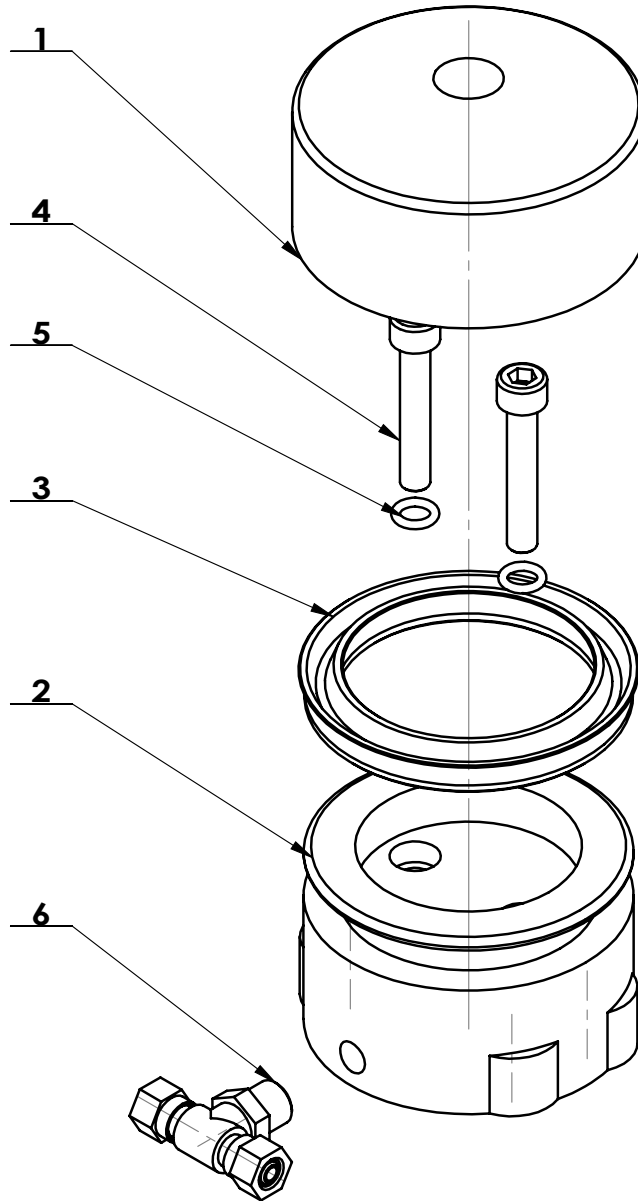

ITEM	PART. No	DESCRIPTION.	QT. Y
1	C-70-1223001	LOCK TURNTABLE CYLINDER HEAD	1
2	C-70-1223002	LOCK TURNTABLE CYLINDER HOUSING	1
3	C-70-1223003	Y-RING	1
4	GB70. 1-M6×35	INNER HEXA CYLINDRICAL SCREW	2
5	GB3452. 1-6×1.8-G	O-RING G TYPE	2
6	PBS 6-01	MALE BRANCH TEE NUT	1

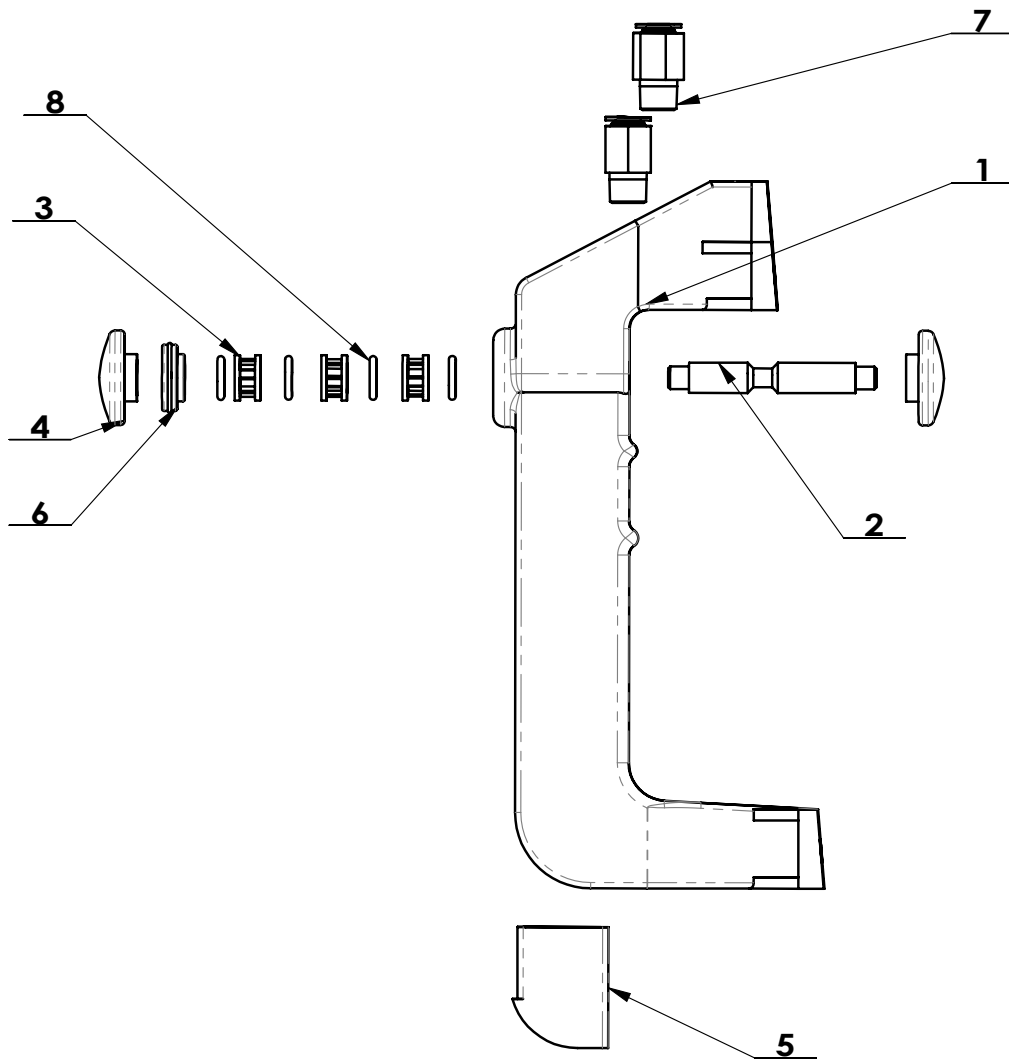

ITEM	PART. No	DESCRIPTION.	QT. Y
1	C-70-1224001	HANDLE CONTROL VALVE	1
2	C-70-1224002	VALVE ROD	1
3	C-70-1224003	VALVE SPACER	3
4	C-70-1224004	FRONT COVER	2
5	C-70-1224005	REAR COVER	1
6	C-70-1224006	FRONT SEALING COVER	1
7	FPC 6-01	MALE STRAIGHT	2
8	GB3452. 1-8×1.8-G	O-RING G TYPE	4

REVISION A-08

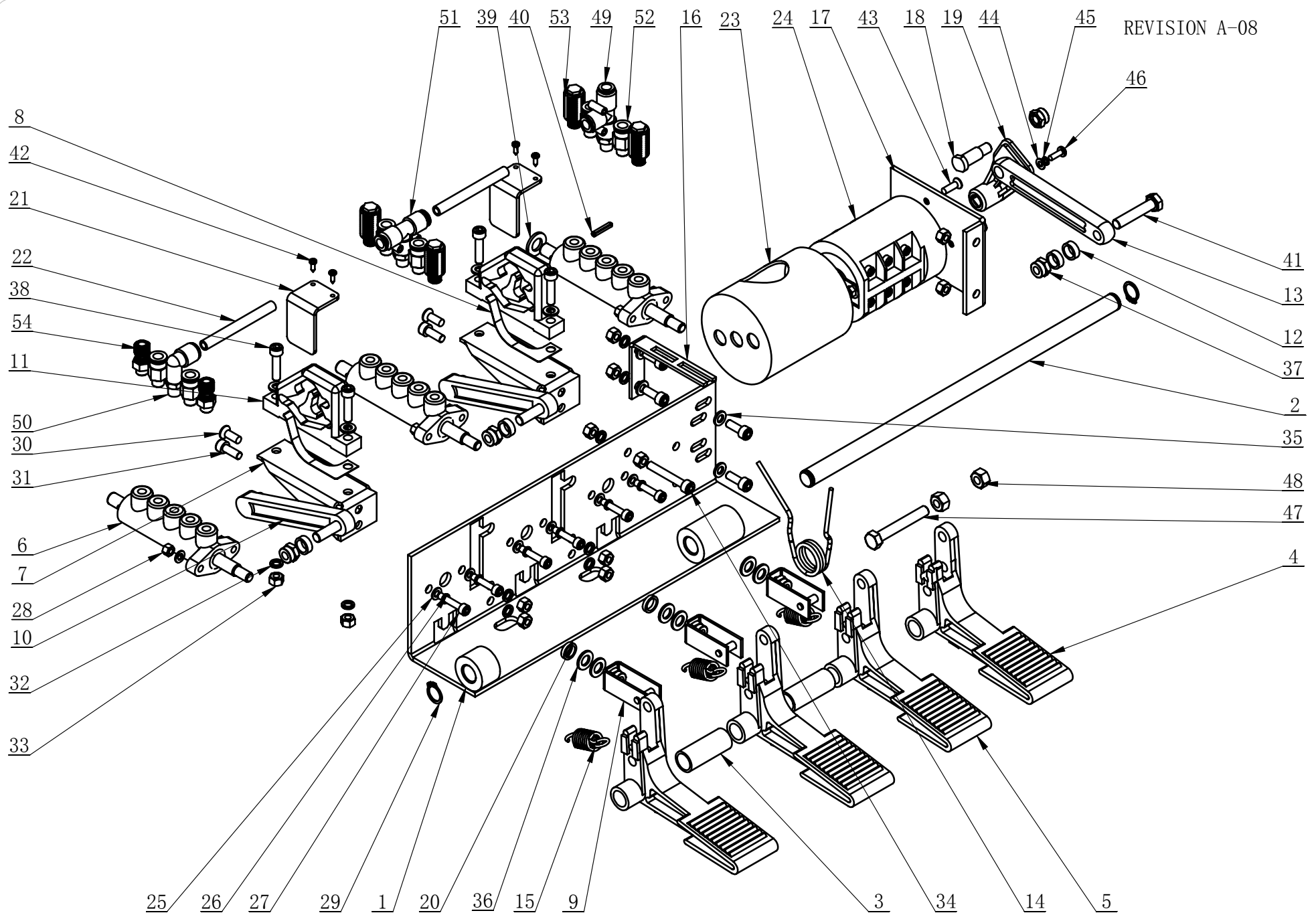

ITEM	PART. No	DESCRIPTION.	QT. Y
1	CT-D-4110000	PEDAL SUPPORT WELDING	1
2	CT-D-4100001	BOTTOM SHAFT	1
3	CT-D-2100001	SPACER	2
4	CT-D-2100006	PEDAL	1
5	CT-D-2100007	PEDAL	3
6	CT-D-2140000	VALVE	3
7	CT-D-2120000	CAM BRACKET WELDING	2
8	CT-D-2100004	SPRING PLATE	2
9	CT-D-2130000	BRACKET RIVETING	3
10	CT-D-1100008	CAM CONNECTING ROD	2
11	CT-D-1100009	CAM	2
12	CT-D-2100005	SPACER	4
13	CT-D-2100011	CONNECTION ROD	1
14	CT-D-2100002	TORSION SPRING	1
15	CT-D-2100003	SPRING	3
16	CT-D-2100010	TORSION SPRING BRACKET	1
17	CT-D-2100008	SWITCH SUPPORT	1
18	CT-D-2100012	ROTATION SHAFT	1
19	CT-D-1100010	REVERSE LEVER	1
20	CT-D-1100016	SPACER	2
21	CT-D-1100011	CAM BAFFLE PLATE	2
22	CT-D-2100013	HOSE	2
23	CT-D-1100014	SWITCH COVER	1
24	CT-D-1100018	SWITCH	1
25	GB95-5	FLAT WASHER	12
26	GB93-5	STANDARD SPRING WASHER	6
27	GB70. 1-M5×25	INNER HEXA CYLINDRICAL SCREW	6
28	GB41-M5	HEXANGULAR NUT	6
29	GB894. 1-14	SHAFT ELATIC BIG RETAINING RING A-TYPE	2
30	GB819. 1-M6×16-H	CROSS COUNTERSUNK SCREW STEEL 4.8 GRADE	2
31	GB70. 1-M6×16	INNER HEXA CYLINDRICAL SCREW	6
32	GB93-6	STANDARD SPRING WASHER	11
33	GB41-M6	HEXANGULAR NUT	14
34	GB70. 1-M6×40	INNER HEXA CYLINDRICAL SCREW	1
35	GB95-6	FLAT WASHER	8
36	GB95-8	FLAT WASHER	6
37	GB889. 1-M8	1-TYPE PREVAILING TORQUE TYPE HEXAGON LOCK NUT	7
38	GB70. 1-M6×25	INNER HEXA CYLINDRICAL SCREW	4
39	GB95-10	FLAT WASHER	1
40	GB879. 1-4×20	ELASTIC CYLINDRICAL PIN, HEAVY	1
41	GB5781-M8×40	HEXANGULAR BOLT	1
42	GB845-ST2. 9×9.5 H C	CROSS PANHEAD TAPPING SCREW	4
43	GB819. 1-M5×16-H	CROSS COUNTERSUNK SCREW STEEL 4.8 GRADE	4
44	GB95-4	FLAT WASHER	1
45	GB93-4	STANDARD SPRING WASHER	1
46	GB818-M4×12-H	CROSS PANHEAD SCREW	1
47	GB5782-M8×55	HEXANGULAR BOLT	1
48	GB41-M8	HEXANGULAR NUT	2
49	FPD 8-01	MALE RUN TEE	1
50	FPL 8-01	INSERT ELBOW Φ8, R1/8	1
51	FPB 8-01	MALE BRANCH TEE	1
52	FPC 8-01	MALE STRAIGHT	6
53	FSK 01	PLASTIC PARTICLE SILENCER	4
54	FJSR 01	BRASS REGULATOR SILENCER	2

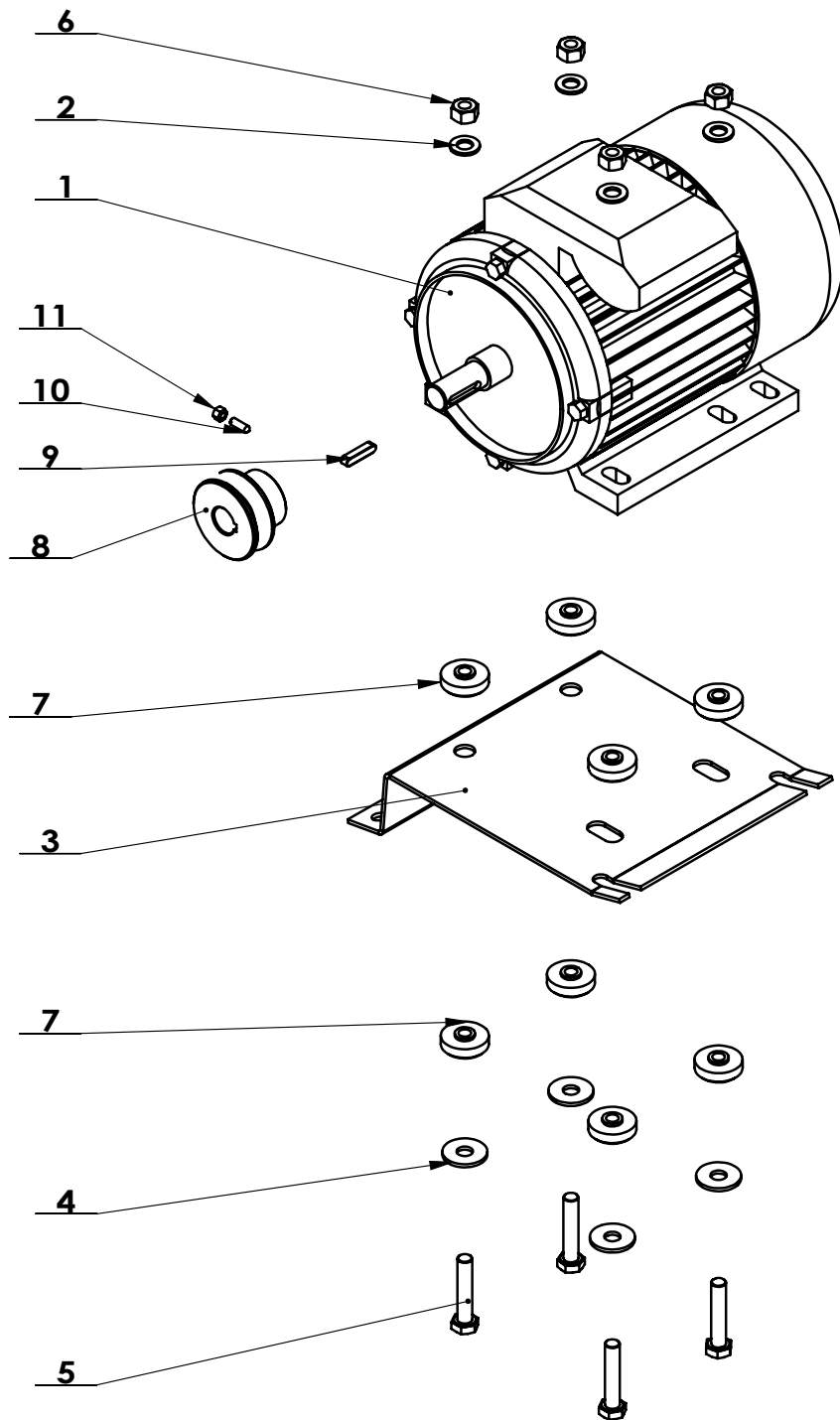

ITEM	PART. No	DESCRIPTION.	QT. Y
1	CT-DJ-0018112	MOTOR(1.1KW220-240V50Hz)	1
2	GB95-10	FLAT WASHER	4
3	CT-DJ-0000001	MOTOR SUPPORT	1
4	GB96.2-10	LARGE WASHER C GRADE	4
5	GB5781-M10×50	HEXANGULAR BOLT	4
6	GB41-M10	HEXANGULAR NUT	4
7	CT-DJ-0000002	RUBBER WASHER	8
8	CT-DJ-0000003	MOTOR BELT PULLEY	1
9	GB1096-6×6×28	COMMON FLAT KEY	1
10	GB71-M5×16	SLOTTED CONIC HEAD SET SCREW	1
11	GB41-M5	HEXANGULAR NUT	1

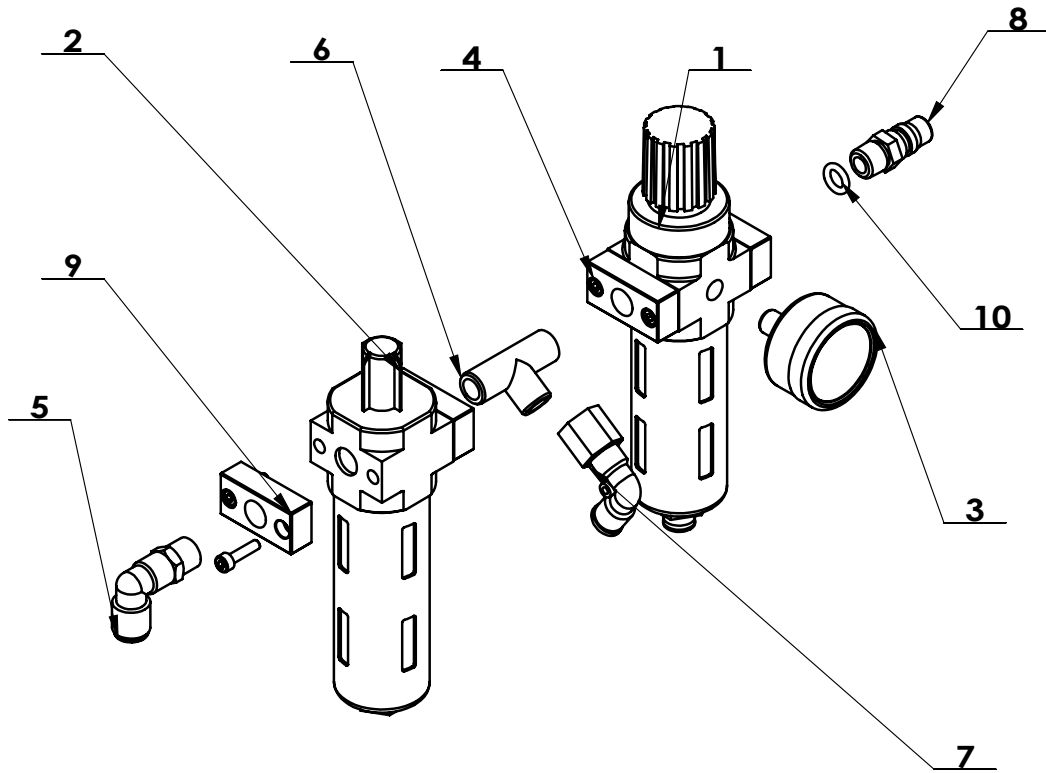

ITEM	PART. No	DESCRIPTION.	QT. Y
1	CT-F-2000001	PRESSURE ADJUST VALVE AND WATER CUP	1
2	CT-F-2000002	OIL CUP	1
3	CT-F-2000003	PRESSURE GAUGE	1
4	GB70. 1-M4×16	INNER HEXA CYLINDRICAL SCREW	8
5	FPL 8-02	INSERT ELBOW Φ8, R1/4	1
6	PEH 1-4	TEE R1/4	1
7	PLF8-02	INSERT ELBOW φ8, R1/4	1
8	C-01-100000D	AIR SUPPLY CONNECTOR	1
9	CT-F-2000004	CONNECT	4
10	GB3452. 1-8×2.65-A	O-RING G TYPE	1

GEARBOX ASSEMBLY

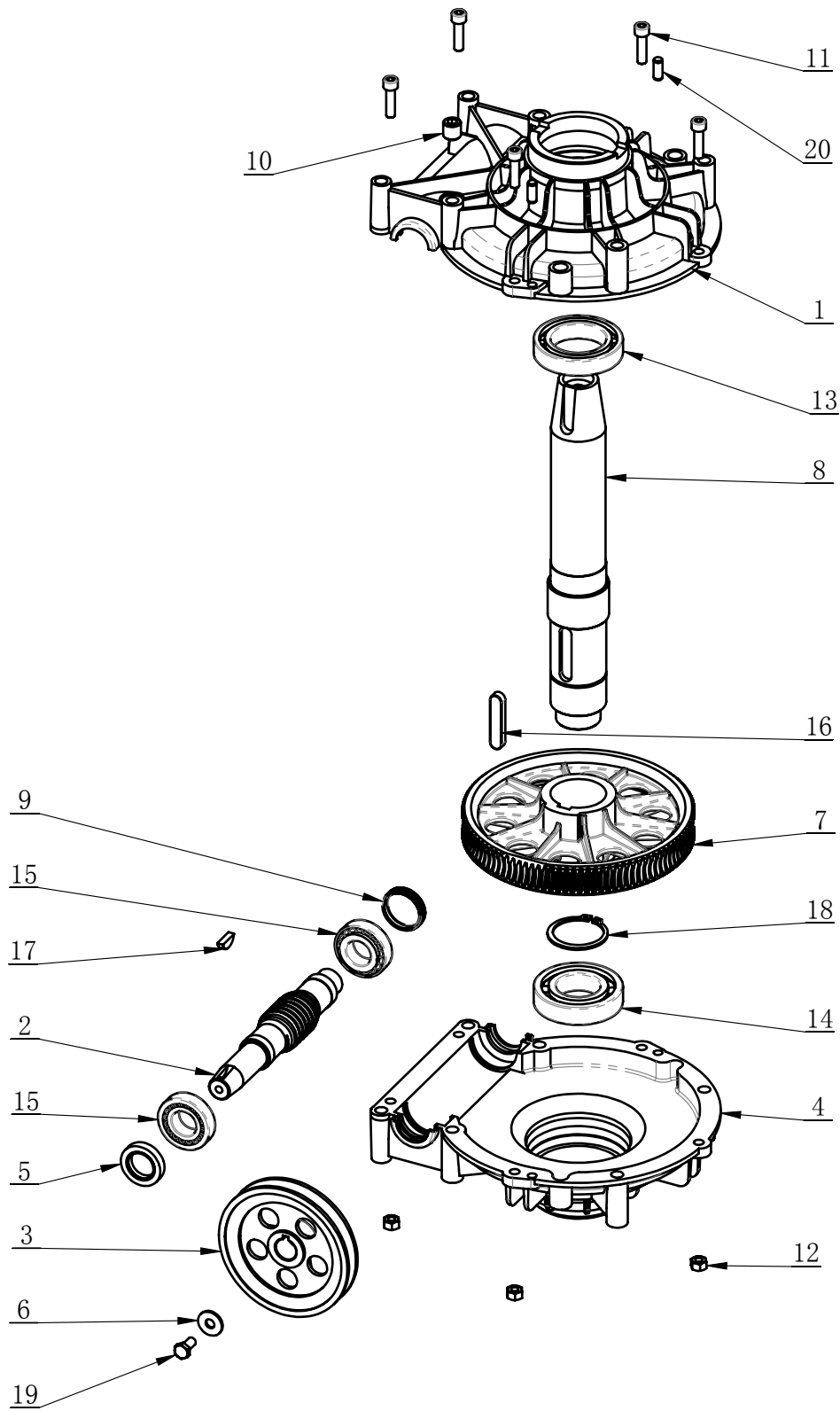

ITEM	PART. No	DESCRIPTION.	QT. Y
1	CT-J-0000006	GEARBOX TOP	1
2	CT-J-0000004	WORM ROD	1
3	CT-J-0000008	BELT PULLEY	1
4	CT-J-0000005	GEARBOX TOP	1
5	FB25-40 GB13871.92	SEALED RING	1
6	GB96.2-8	LARGE WASHER C GRADE	1
7	CT-J-0000003	WORM	1
8	CT-J-0000002	WORM SHAFT	1
9	CT-J-0100000	CAP	1
10	GB77-M16X1.5-16	SCREW	1
11	GB70.1-M8×30	INNER HEXA CYLINDRICAL SCREW	5
12	GB41-M8	HEXANGULAR NUT	5
13	GB276-6010	DEEP GROOVE BALL BEARINGS	1
14	GB276-6208	DEEP GROOVE BALL BEARINGS	1
15	GB297-30205	CYLINDRICAL BALL BEARING	2
16	GB1096-12×8×56	COMMON FLAT KEY	1
17	GB1099.1-6×9×22	COMMON SEMI-CIRCULAR KEY	1
18	GB894.1-50	SHAFT ELATIC BIG RETAINING RING A-TYPE	1
19	GB5781-M8×16	HEXANGULAR BOLT	1
20	GB119.1-8×20	CYLINDRICAL PIN	2

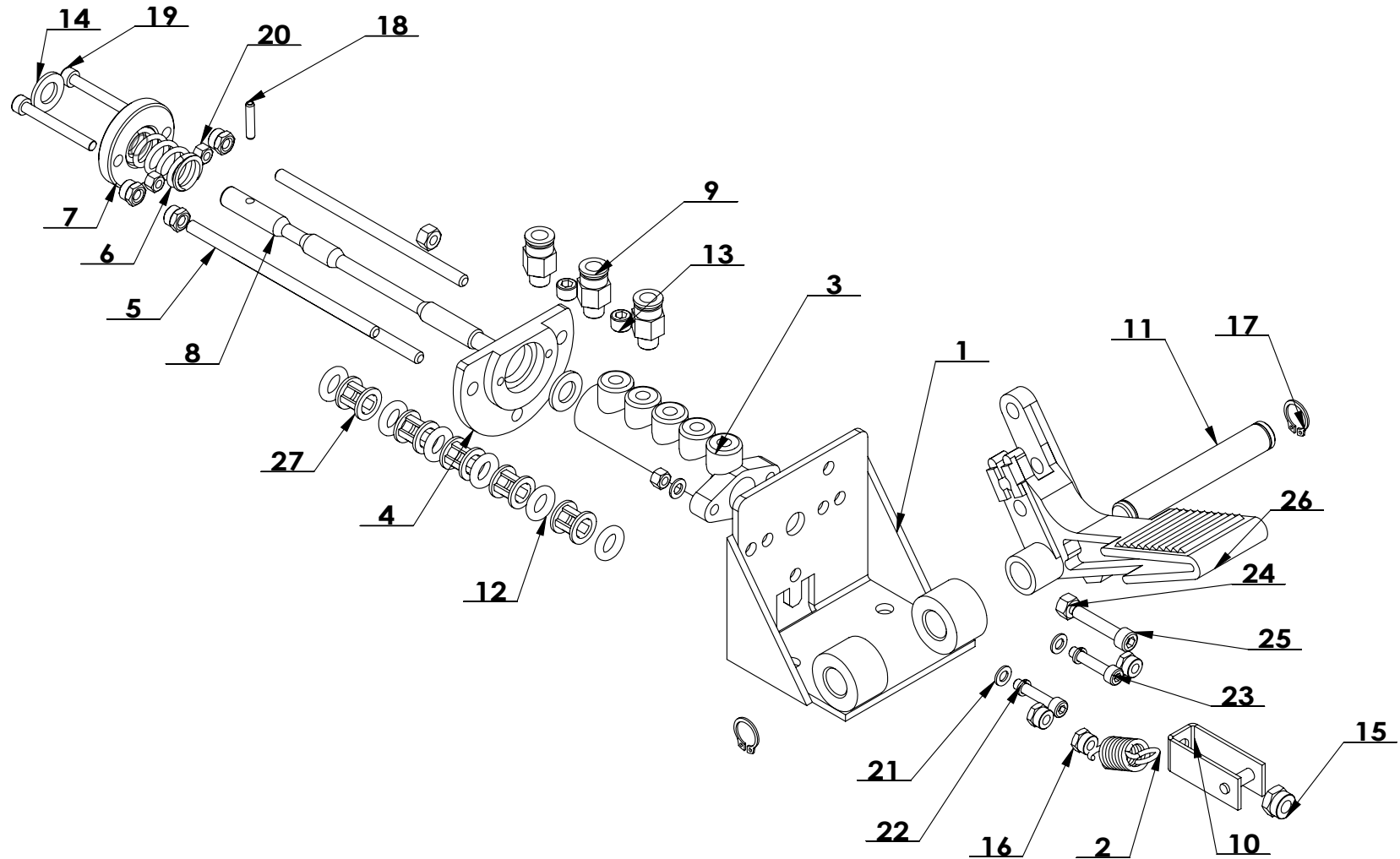

ITEM	PART. No	DESCRIPTION.	QT. Y
1	CT-K-1110000	BRACKET	1
2	CT-D-2100003	SPRING	1
3	CT-D-2140002	VALVE BODY	1
4	CT-K-1100004	FIXTURE PLATE	1
5	CT-K-1100005	BOLT	3
6	CT-K-1100003	SPRING	1
7	CT-K-1100002	MOVABLE PLATE	1
8	CT-K-1100001	VALVE ROD	1
9	FPC 8-01	MALE STRAIGHT	3
10	CT-D-2130000	BRACKET RIVETING	1
11	CT-K-1100006	SHAFT	1
12	CT-D-1110003	O-RING	6
13	FPS 01	PLUG MAIN BLOCK	2
14	GB95-10	FLAT WASHER	2
15	GB889. 1-M8	1-TYPE PREVAILING TORQUE TYPE HEXAGON LOCK NUT	1
16	GB889. 1-M6	1-TYPE PREVAILING TORQUE TYPE HEXAGON LOCK NUT	6
17	GB894. 1-14	SHAFT ELATIC BIG RETAINING RING A-TYPE	2
18	GB879. 1-4×20	ELASTIC CYLINDRICAL PIN, HEAVY	1
19	GB70. 1-M5×45	INNER HEXA CYLINDRICAL SCREW	2
20	GB41-M5	HEXANGULAR NUT	4
21	GB95-5	FLAT WASHER	4
22	GB93-5	STANDARD SPRING WASHER	2
23	GB70. 1-M5×25	INNER HEXA CYLINDRICAL SCREW	2
24	GB41-M6	HEXANGULAR NUT	2
25	GB70. 1-M6×30	INNER HEXA CYLINDRICAL SCREW	1
26	CT-D-2100006	PEDAL	1
27	CT-D-1110004	SPACER	5

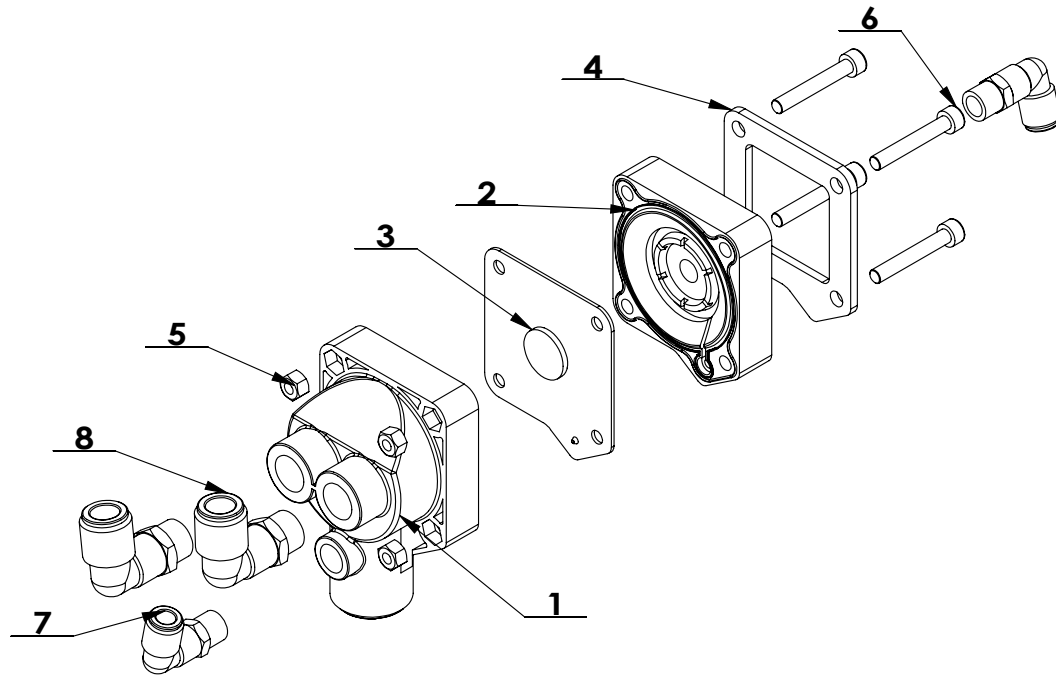

ITEM	PART. No	DESCRIPTION.	QT. Y
1	CT-K-2200002	LOWER COVER OF QUICK DEFLATE VALVE	1
2	CT-K-2200001	COVER OF QUICK DEFLATE VALVE	1
3	CT-K-2210000	FILM CHIP	1
4	CT-K-2200003	PRESS WASHER	1
5	GB41-M6	HEXANGULAR NUT	4
6	GB70. 1-M6×40	INNER HEXA CYLINDRICAL SCREW	4
7	FPL 8-02	INSERT ELBOW Φ8, R1/4	2
8	FPL 12-03	INSERT ELBOW Φ12 R3/8"	2

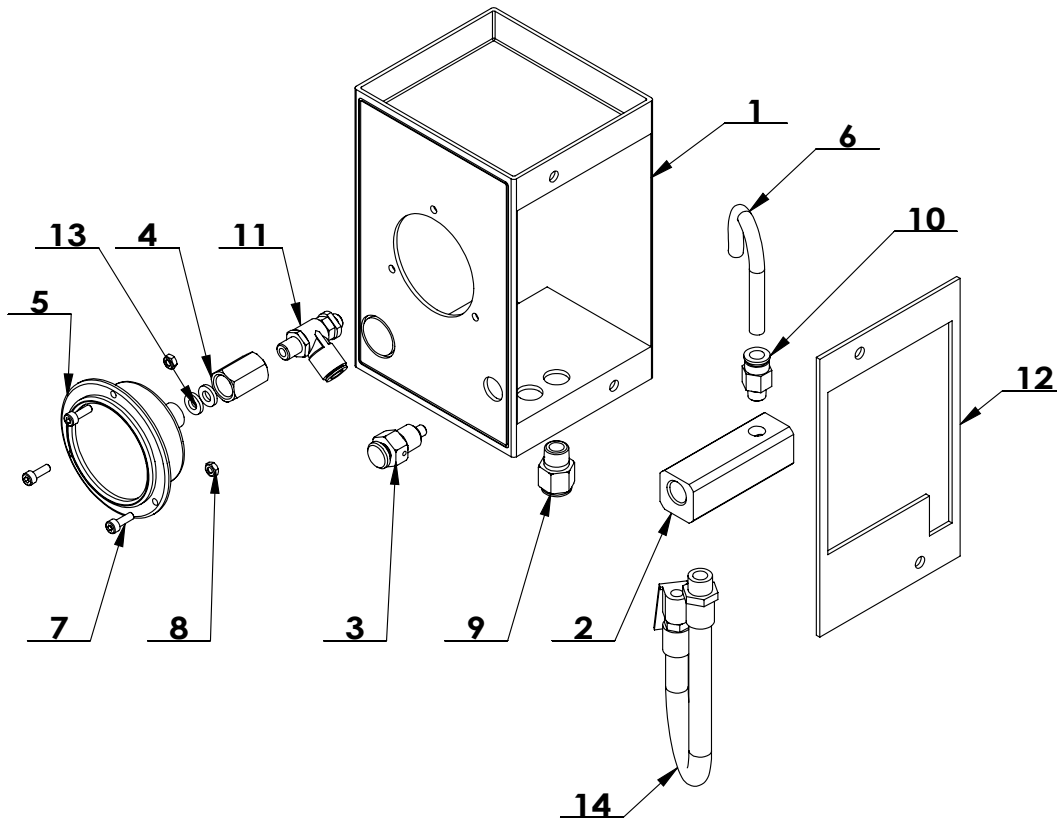

ITEM	PART. No	DESCRIPTION.	QT. Y
1	CT-K-3100001	PRESSURE GAUGE COVER	1
2	CT-K-3120000	AIR DISTRIBUTING VALVE	1
3	CT-K-3110000	EXHAUST VALVE ASSEMBLY	1
4	CT-K-3100002	CONNECT NUT	1
5	CT-K-3100004	PRESSURE GAUGE	1
6	PU $\Phi 8 \times 5-160$	PU HOSE $\Phi 8 \times 5$	1
7	GB70. 1-M4 \times 12	INNER HEXA CYLINDRICAL SCREW	3
8	GB6170-M4	HEXANGULAR NUT 1-TYPE	3
9	FPC 8-02	MALE STRAIGHT	1
10	FPC 8-01	MALE STRAIGHT	1
11	FJSC 8-01 (JQ)	ELBOW SPEED CONTROLLER	1
12	CT-K-3100005	SIDE PANEL	1
13	TC-10-1620003	AIR REGULATOR WASHER	2
14	CT-K-3100003	1.5m INFLATION HOSE	1

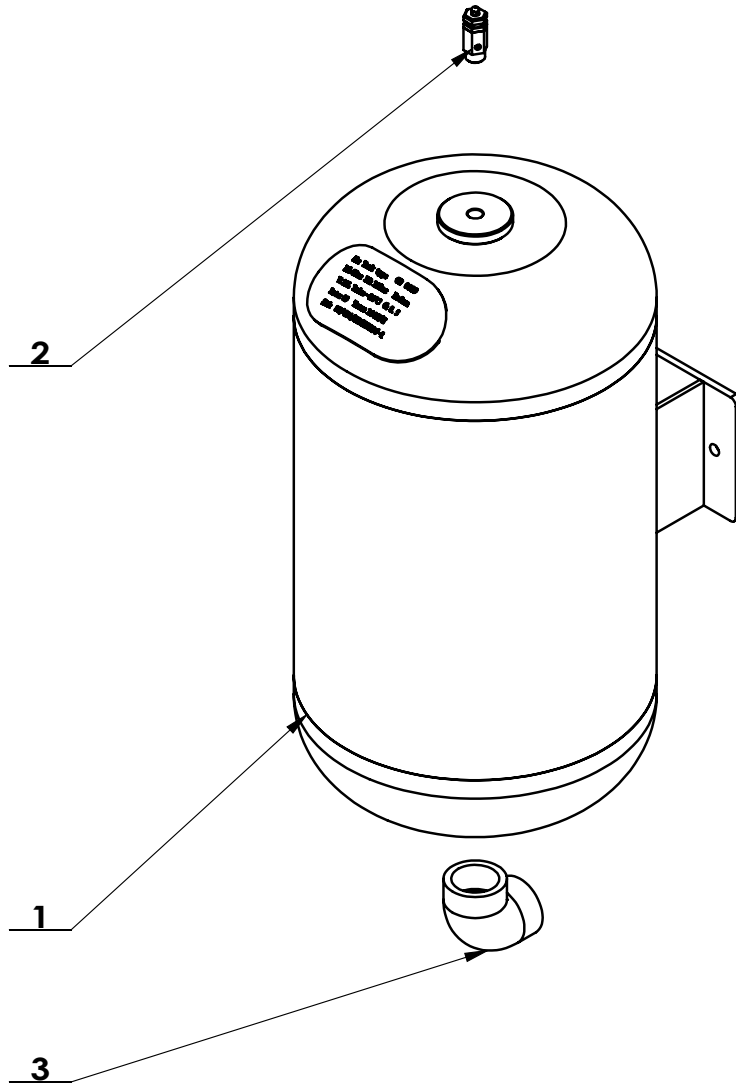

ITEM	PART. No	DESCRIPTION.	QT. Y
1	CT-K-4110000	AIR TANK	1
2	CT-K-4100001	SAFE VALVE	1
3	CT-K-4100002	ELBOW_90, G1"	1

REVISION A-02

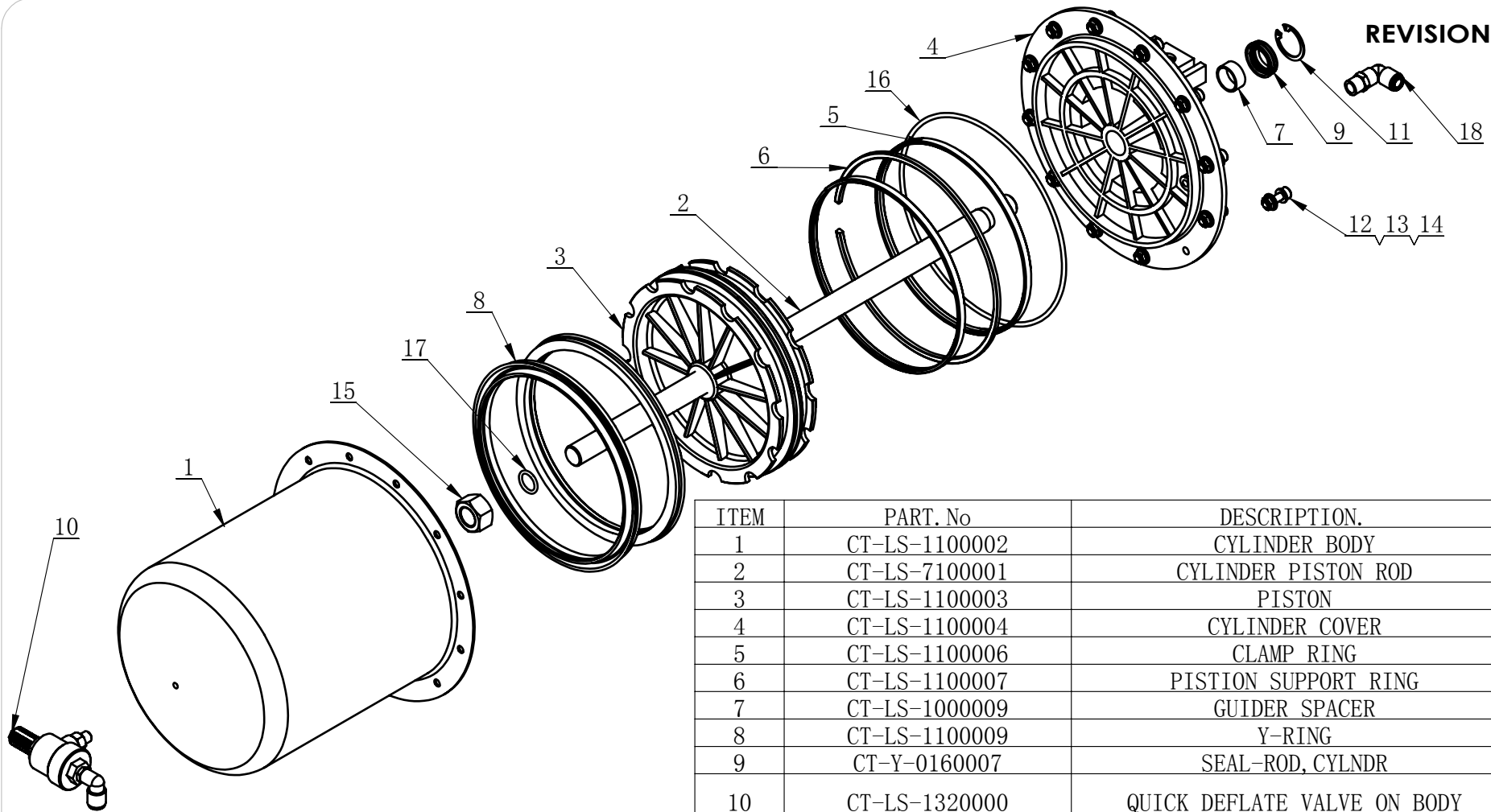

ITEM	PART. No	DESCRIPTION.	QT. Y
1	CT-LS-1100002	CYLINDER BODY	1
2	CT-LS-7100001	CYLINDER PISTON ROD	1
3	CT-LS-1100003	PISTON	1
4	CT-LS-1100004	CYLINDER COVER	1
5	CT-LS-1100006	CLAMP RING	2
6	CT-LS-1100007	PISTON SUPPORT RING	1
7	CT-LS-1000009	GUIDER SPACER	1
8	CT-LS-1100009	Y-RING	2
9	CT-Y-0160007	SEAL-ROD, CYLNR	1
10	CT-LS-1320000	QUICK DEFLATE VALVE ON BODY	1
11	GB893. 2-30	ELASTIC RETAINING RING B-TYPE	1
12	GB70. 1-M6×20	INNER HEXA CYLINDRICAL SCREW	12
13	GB95-6	FLAT WASHER	12
14	GB6177. 1-M6	HEXA FLANGE NUT	12
15	GB6171- M18×1.5	NUT THIN TOOTH	1
16	GB3452. 1-185×3.55-G	O-RING G TYPE	1
17	GB3452. 1-15.5×2.65-G	HYDRAULIC-PNEUMATIC RUBBER O-RING G TYPE	1
18	FPL 8-02	INSERT ELBOW Φ8, R1/4	1

CT-LS-7400000

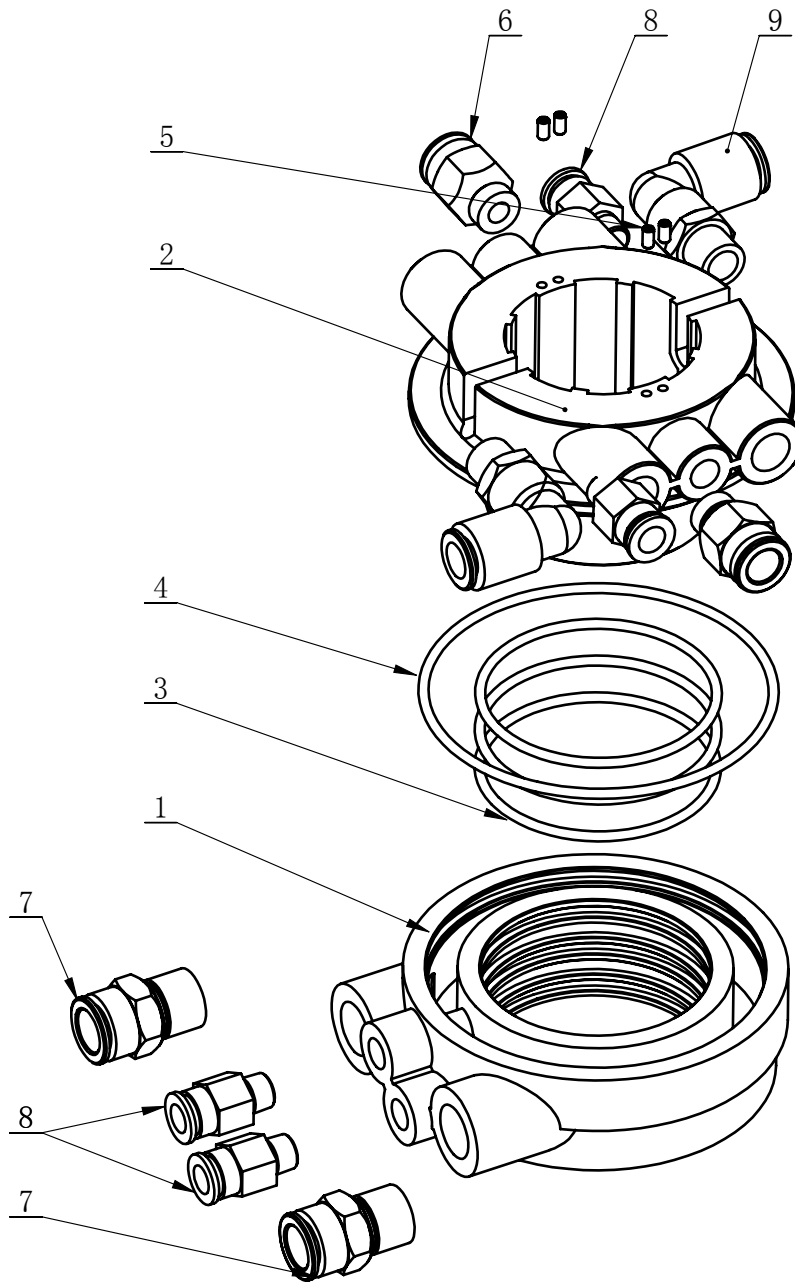

ITEM	PART. No	DESCRIPTION.	QT. Y
1	CT-Q-2000002	AIR GUIDE EXTERNAL BUSHING	1
2	CT-Q-2000001	AIR GUIDE ROTATION BUSHING	1
3	GB3452. 1-60×2.65-G	HYDRAULIC-PNEUMATIC RUBBER O-RING G TYPE	3
4	GB3452. 1-90×2.65-G	HYDRAULIC-PNEUMATIC RUBBER O-RING G TYPE	1
5	GB73-M3×6	SLOTTED FLATTEN HEAD SET SCREW	4
6	FPC 10-02	MALE STRAIGHT	2
7	FPC 12-03	MALE STRAIGHT	2
8	FPC 8-01	MALE STRAIGHT	4
9	FPL 10-02	MALE ELBOW	2

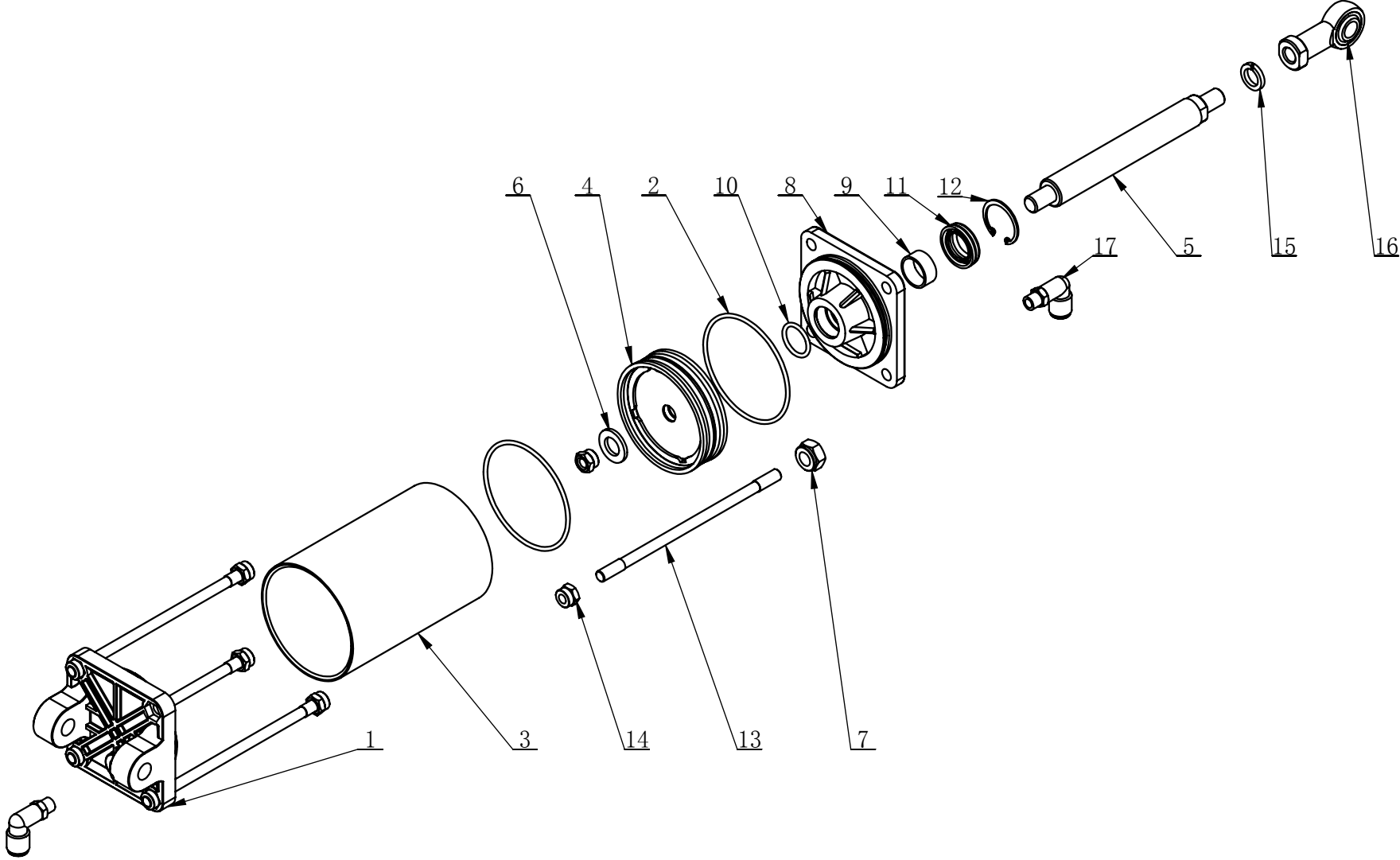

ITEM	PART. No	DESCRIPTION.	QT. Y
1	CT-XD-1000005	CYLINDER REAR COVER	1
2	GB3452. 1-75×2. 65-G	HYDRAULIC-PNEUMATIC RUBBER O-RING G TYPE	2
3	CT-XD-1000001	CYLINDER	1
4	CT-Y-6610000	PISTON	1
5	CT-XD-1000006	SHAFT-CLYNDR	1
6	GB95-12	FLAT WASHER	1
7	GB889. 1-M12	1- TYPE PREVAILING TORQUE TYPE HEXAGON LOCK NUT	1
8	CT-Y-6600001	CYLINDER FRONT COVER	1
9	JH1 2010	BEARING-SLIDE	1
10	GB3452. 1-20×2. 65-G	HYDRAULIC-PNEUMATIC RUBBER O-RING G TYPE	1
11	BYXQ30x20x7	SEAL-ROD, CYLNR	1
12	GB893. 1-30	ELASTIC RETAINING RING A-TYPE	1
13	CT-XD-1000003	BARS	4
14	GB889. 1-M8	1-TYPE PREVAILING TORQUE TYPE HEXAGON LOCK NUT	8
15	GB93-12	STANDARD SPRING WASHER	1
16	CT-XD-1000007	SHAFT END KNUCKLE BEARING	1
17	BNCWT8-G1 / 8	INSERT ELBOW $\Phi 8$, R1/8	2

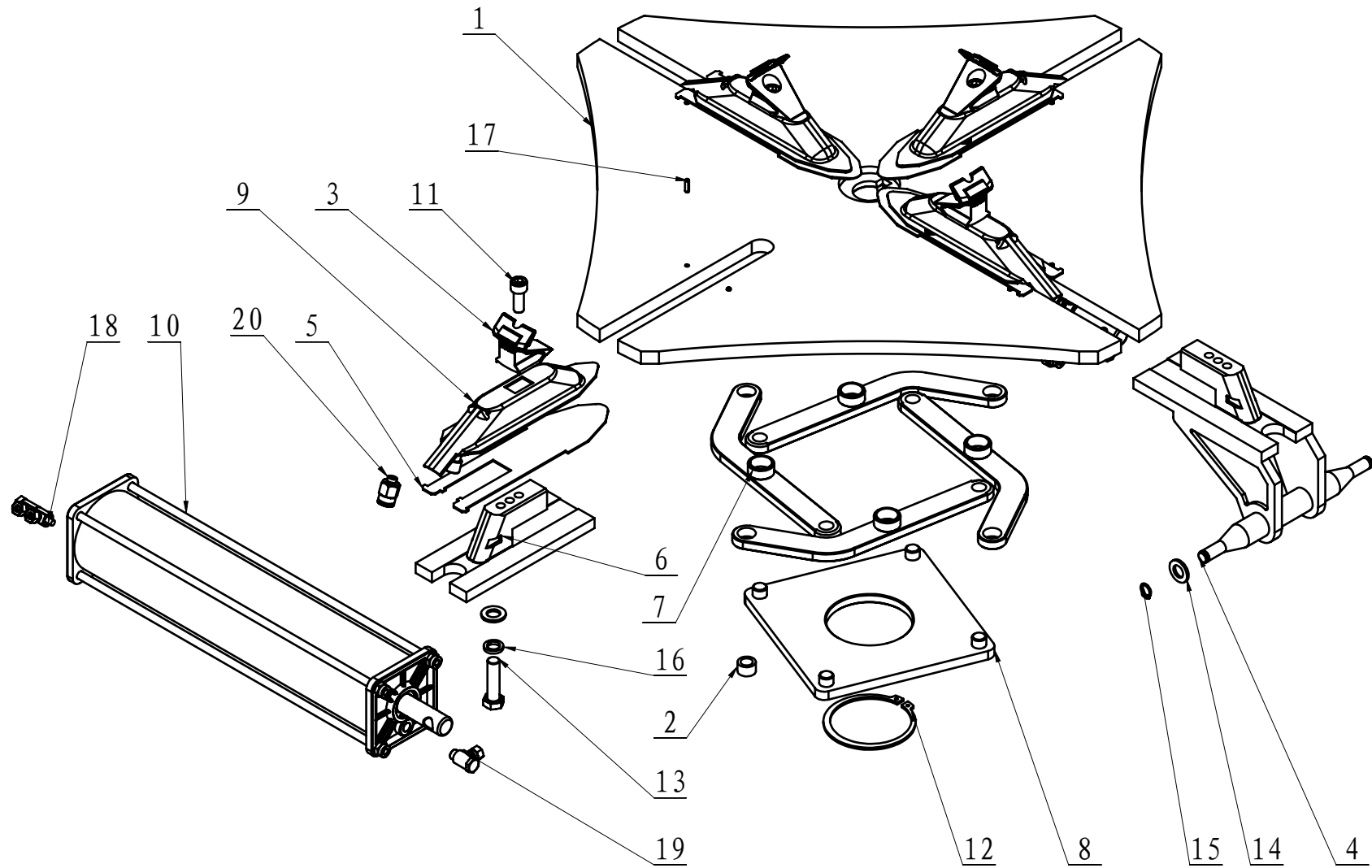

ITEM	PART. No	DESCRIPTION.	QT. Y
1	CT-Y-5110000	TURNTABLE	1
2	CT-Y-0100003	SPACER	4
3	CT-Y-5100002	CLAMP	4
4	CT-Y-5130000	BRACKET-CYLINDER	2
5	CT-Y-5100003	WEARABLE WASHER	4
6	CT-Y-5100001	PRESS BOARD	2
7	CT-Y-6400000	CONNECTION PLATE	4
8	CT-Y-6500000	SQUARE TURNTABLE	1
9	CT-Y-5120000	SLIDE COVER	4
10	CT-Y-6600000	CYLINDER ASSEMBLY D80X350	2
11	GB70. 1-M10 × 25	INNER HEXA CYLINDRICAL SCREW	4
12	GB894. 1-85	SHAFT ELATIC BIG RETAINING RING A-TYPE	1
13	GB5781-M12 × 45	HEXANGULAR BOLT	4
14	GB95-12	FLAT WASHER	8
15	GB894. 1-12	SHAFT ELATIC BIG RETAINING RING A-TYPE	4
16	GB93-12	STANDARD SPRING WASHER	4
17	GB879. 1-4 × 14	ELASTIC CYLINDRICAL PIN HEAVY	8
18	CT-Y-6000008	HINGE TEE Φ8 R1/8"	2
19	CT-Y-6000007	HINGE ELBOW Φ8 R1/8"	2
20	FPC 10-01	MALE STRAIGHT	4

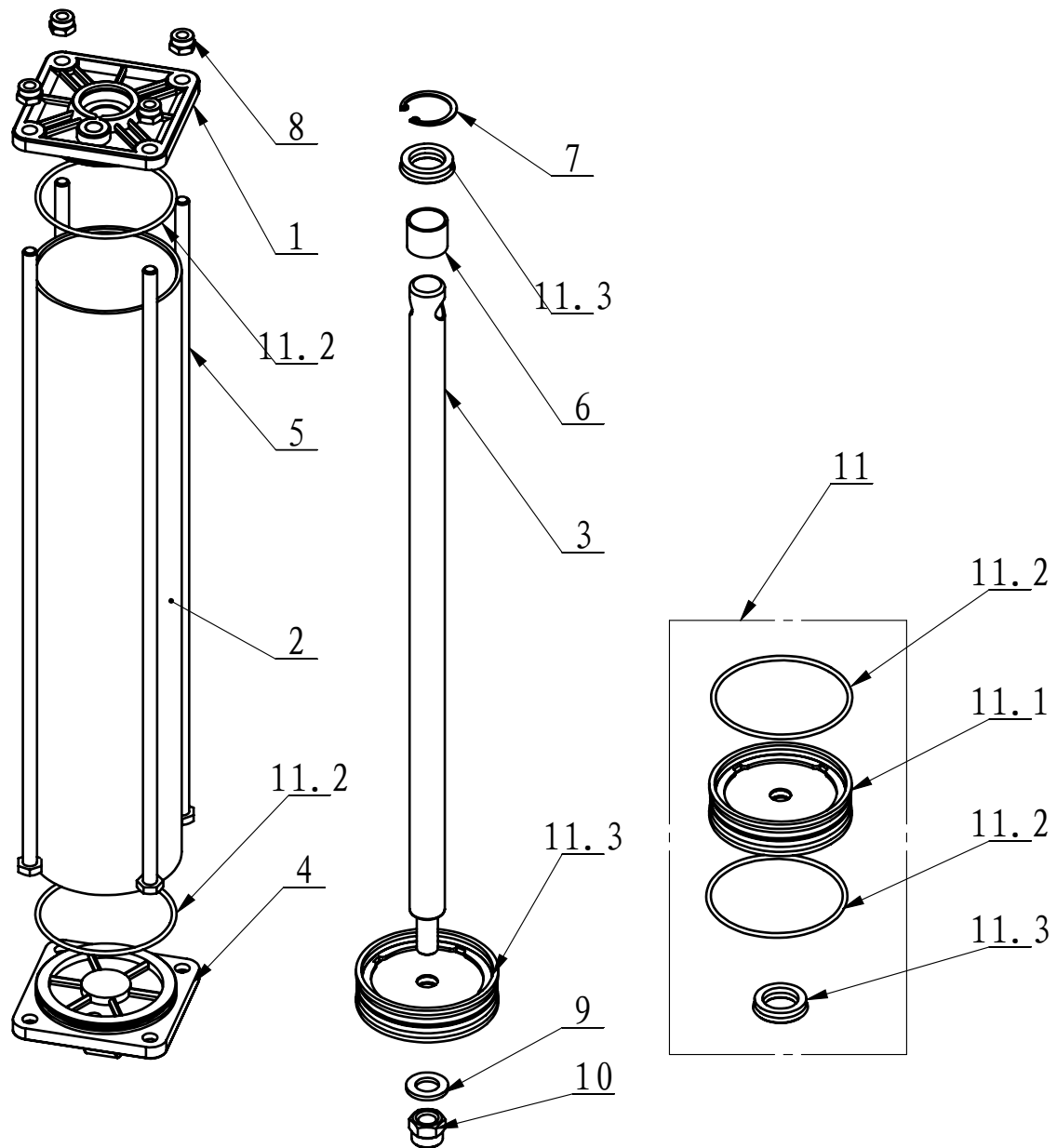

ITEM	PART. No	DESCRIPTION.	QT. Y
1	CT-Y-6600001	CYLINDER FRONT COVER	1
2	CT-Y-6600002	CYLINDER 80MM	1
3	CT-Y-6600003	SHAFT-CLYDR	1
4	CT-Y-6600005	CAP-BASE, CYLNDR	1
5	CT-Y-6600006	BOLT	4
6	JH1 2020	BEARING-SLIDE	1
7	GB893. 1-30	ELASTIC RETAINING RING A-TYPE	1
8	GB889. 1-M8	1-TYPE PREVAILING TORQUE TYPE HEXAGON LOCK NUT	4
9	GB95-12	FLAT WASHER	1
10	GB889. 1-M12	1- TYPE PREVAILING TORQUE TYPE HEXAGON LOCK NUT	1
11	CT-Y-6620000	CYCLINDER SEALING PARTS ASSEMBLY	1
11.1	CT-Y-6610000	PISTON	1
11.2	GB3452. 1-75×2.65-G	HYDRAULIC-PNEUMATIC RUBBER O-RING G TYPE	2
11.3	CT-Y-0160007	SEAL-ROD, CYLNDR	1

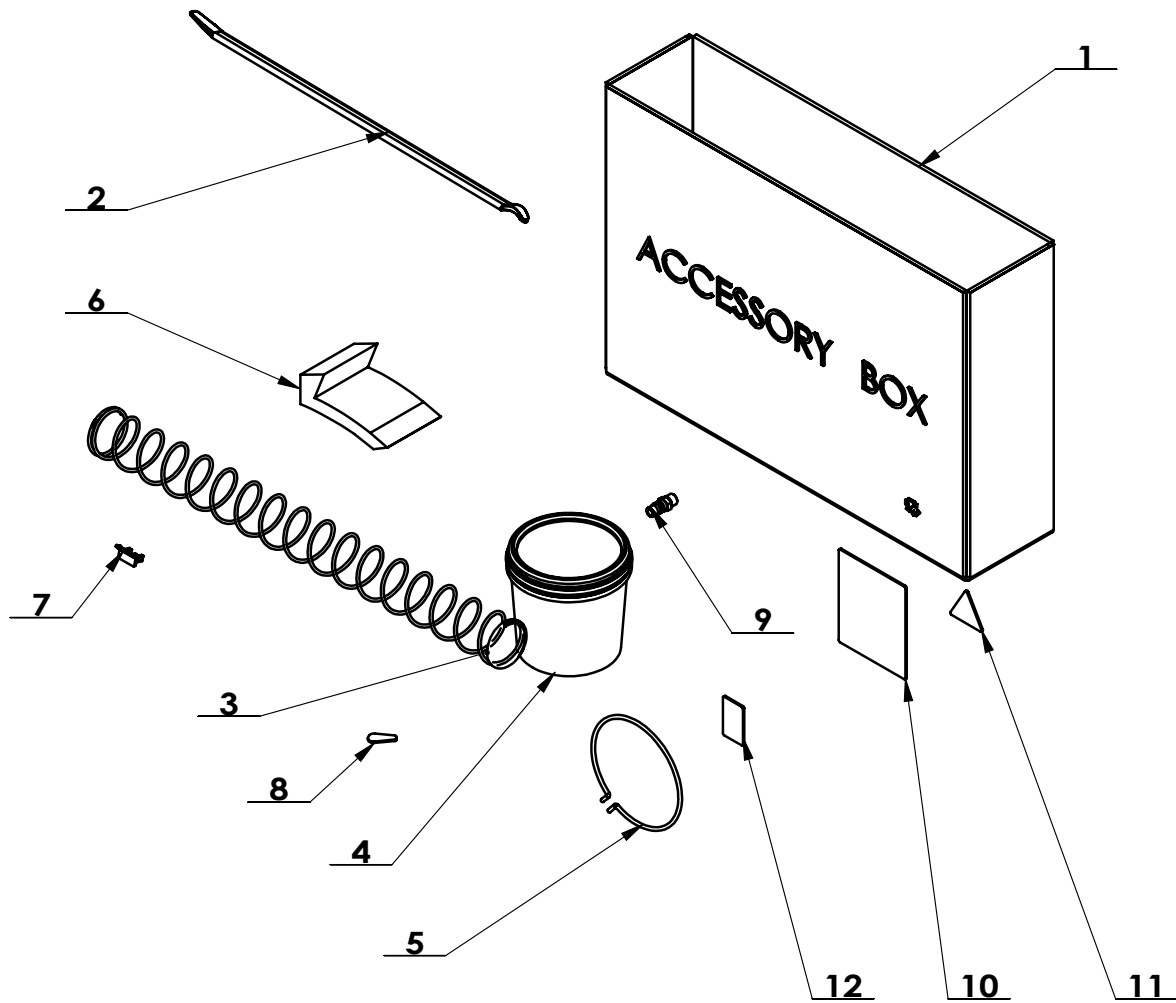

ITEM	PART. No	DESCRIPTION.	QT. Y
1	C-01-8000001	ACCESSORY BOX	1
2	C-01-1000008	CROWBAR 20 "	1
3	C-80-1320003	VERTICAL SHAFT SPRING	1
4	C-01-1300000	GREASE CONTAINER	1
5	C-01-1000005	BRACKET	1
6	C-01-8000002	CLAMP PROTECTION COVER	5
7	C-31-1300014	SHEATH	2
8	C-31-1300015	PLASTIC COVER	1
9	C-01-100000D	AIR SUPPLY CONNECTOR	1
10	C-31-8000001	USER MANUAL	1
11	C-31-8000002	PASS CARD	1
12	C-31-8000003	GUARANTEE	1