

KWIK-WAY®

540

Telescoping Tilt-Tower Tire Changer



Instruction Manual and Parts List

KW Products Inc.
500 57th Street, Marion, IA 52302 USA
Copyright 2004 All Rights Reserved
Equipment specifications, options and accessories subject to change without

800-553-5953

540 TIRE CHANGER



521 WARRANTY Brake Lathes · Tire Changers · Wheel Balancers

KW Products Inc. (Kwik-Way) provides a limited 521 Warranty on products when purchased in a new and unused condition to be free from defective material or workmanship from date of purchase as per the following:

Product Category	BENCH MODEL LATHES	ON-CAR-LATHES	PASSENGER CAR TIRE CHANGERS	WHEEL BALANCERS	TRUCK LATHES AND TIRE CHANGERS
5 Years	Spindle, spindle bearing and housing	Cast iron components, excluding guide rods	Transmission	Frame, welding construction	N/A
2 Years	All other mechanical parts	All other mechanical parts	All other mechanical parts	All other mechanical parts	N/A
1 Year	Motor, electronic components and labor	Motor, electronic components and labor	Motor, electronic components and labor	Motor, electronic components and labor	Machine, components and labor

Kwik-Way will repair and/or replace, free of charge (FOB factory) all such defective parts, only when returned to factory with shipping charges prepaid. This warranty does not cover parts and supplies consumed in normal operation of the machine.

Kwik-Way disclaims all other warranties, expressed or implied, as to the quality of any goods, including implied warranties of MERCHANTABILITY and FITNESS FOR PARTICULAR PURPOSES. UNDER NO CIRCUMSTANCES WHATSOEVER, SHALL *Kwik-Way* BE LIABLE FOR ANY INCIDENTAL OR CONSEQUENTIAL DAMAGES, WHETHER BASED ON LOST GOODWILL, LOST RESALE PROFITS, WORK STOPPAGE, IMPAIRMENT OF OTHER GOODS OR ARISING OUT OF BREACH OF ANY EXPRESS OR IMPLIED WARRANTY, BREACH OF CONTRACT, NEGLIGENCE OR OTHERWISE, EXCEPT ONLY IN THE CASE OF PERSONAL INJURY.

Because of *Kwik-Way's* constant program of product improvement, specifications are subject to change without notice.

This warranty does not apply to a product that has been purchased in used condition, that has failed due to improper installation, repairs, service or that has sustained damage caused by accident, improper use or shipment.

Model #: _____ Serial #: _____

Purchase Date: _____

For further information or questions, please contact *KW Products Inc* at 800/553-5953 or 319/377-9421, fax 319/377-9101, email service@kwik-way.com

KW Products Inc. 800-553-5953
 500 57th Street, Marion, IA 52302 USA
 Copyright 2004 All Rights Reserved
 Equipment specifications, options and accessories subject to change without

540 TIRE CHANGER

RECEIVING SHIPMENT

Upon taking delivery of your machine, carefully inspect the assembly before removing the crating and packing materials.

If evidence of damage exists, contact the shipper and *KW Products Inc.* immediately. Although *KW Products Inc.* is not responsible for damage incurred during transit, you will be provided assistance in preparation and filing of any necessary claims.

CAREFULLY READ THIS MANUAL BEFORE ATTEMPTING TO SETUP OR OPERATE THIS MACHINE.

IMPORTANT NOTE

Always have your serial number ready when communicating with *KW Products Inc.* regarding parts or service.

Keep this manual in a safe place.

Date Received: _____

Serial Number: _____
(Serial Number location: Upper left corner at rear of unit)



540 TIRE CHANGER

SAFETY FIRST

This manual has been prepared for the owner and those responsible for the maintenance of this machine. Its purpose aside from proper maintenance and operations, is to promote safety through the use of accepted practice. **READ THE SAFETY AND OPERATING INSTRUCTIONS THOROUGHLY BEFORE OPERATING THE MACHINE.**

In order to obtain maximum life and efficiency from your machine, follow all the instructions in the operating manuals carefully.

The specifications put forth in this manual were in effect at the time of publication. However, owing to KW Products' policy of continuous improvement, changes to these specifications may be made at any time without obligation.



540 TIRE CHANGER

SAFETY INSTRUCTIONS

1. Read, understand and follow the safety and operating instructions found in this manual. Know the limitations and hazards associated with operating the machine.
2. Eye Safety: Wear an approved safety face shield, goggles or safety glasses to protect eyes when operating the machine.
3. Grounding the Machine: Machines equipped with three prong grounding plugs are so equipped for your protection against shock hazards and should be plugged directly into a properly grounded three-prong receptacle in accordance with national electrical codes and local codes and ordinances. A grounding adapter may be used. If one is used, the green lead should be securely connected to a suitable electrical ground such as a ground wire system. Do not cut off the grounding prong or use an adapter with the grounding prong removed.
4. Work Area: Keep the floor around the machine clean and free of tools, tooling, stock scrap and other foreign material and oil, grease or coolant to minimize the danger of tripping or slipping. Kwik-Way recommends the use of anti-skid floor strips on the floor area where the operator normally stands and that each machine's work area be marked off. Make certain the work area is well lighted and ventilated. Provide for adequate workspace around the machine.
5. Guards: Keep all machine guards in place at all times when machine is in use.
6. Do Not Overreach: Maintain a balanced stance and keep your body under control at all times.
7. Hand Safety: NEVER wear gloves while operating this machine.
8. Machine Capacity: Do not attempt to use the machine beyond its stated capacity or operations. This type of use will reduce the productive life of the machine and could cause the breakage of parts, which could result in personal injury.
9. Avoid Accidental Starting: Make certain the main switch is in the OFF position before connecting power to the machine.
10. Careless Acts: Give the work you are doing your undivided attention. Looking around, carrying on a conversation and horseplay are careless acts that can result in serious injury.
11. Job Completion: If the operation is complete, the machine should be emptied and the work area cleaned.
12. Disconnect All Power and Air to Machine before performing any service or maintenance.
13. Replacement Parts: Use only Kwik-Way replacement parts and accessories; otherwise, warranty will be null and void.
14. Misuse: Do not use the machine for other than its intended use. If used for other purposes, KW Products Inc. disclaims any real or implied warranty and holds itself harmless for any injury or loss that may result from such use

540 TIRE CHANGER

TECHNICAL CHARACTERISTICS

Technical Data

Dimensions	Metric	English
Max. height	1830 mm.	72"
Depth	780 mm.	38"
Width	850 mm.	33.5"
Weight		
Net weight	217 kg	865 lbs.
Gross weight	245 kg	965 lbs.
Electric Motor		
Power		1 HP
Phases		1 PH
Voltage		115V
Bead breaker force	2.500 kg	5,500 lbs.
Noise Level	75 db	
Pneumatic Supply		
Min./max. operating pressure	800-1200 kPa (8-12 bar)	115 / 173 psi

RANGE OF APPLICATIONS

The 540 Tire Changer can operate on wheels having the following minimum and maximum dimensions:

Vehicle Wheel	Min	Max
Wheel width	3"	14"
Rim diameter (locked internally)	12"	26"
Rim diameter (locked externally)	10"	26"
Max. wheel diameter		40"

540 TIRE CHANGER

UNPACKING

On receipt of the packed machine, remove the straps (taking care when cutting them) and packing as in Figure 1. After removing the packing check the machine for missing or damaged parts. If in doubt contact your sales representative or Kwik-Way direct.

Please open and inspect the accessories provided.

NOTE: Discard all non-biodegradable packaging at the appropriate collection points. All packaging materials potentially hazardous to children. Dispose of all materials in a responsible way.

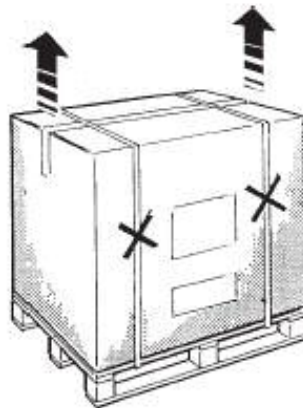

Figure 1

LOCATION OF THE MACHINE

The tire machine must be placed on a solid floor surface, and should not be any closer to a wall or any fixed object than 20". This is to provide for a safe and ergonomic operation of the machine. Figure 2

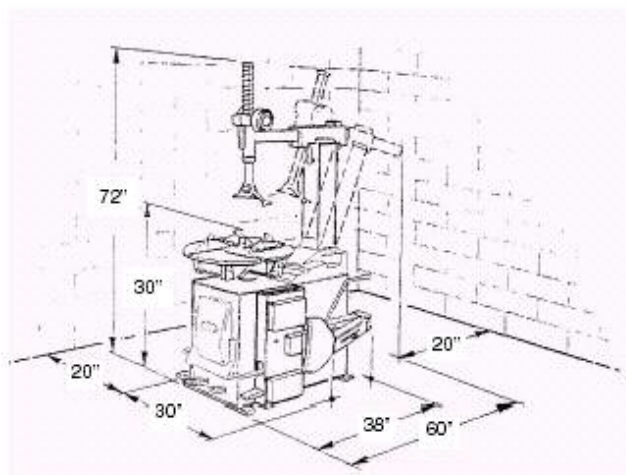

Figure 2

540 TIRE CHANGER

INSTALLATION

Check the voltage at the wall outlet to be used to verify voltage supply matches the voltage on the electrical tag located at the rear of the machine by the cord set.

Attach the air supply to the air regulator at the rear of the machine. Check to verify that there are no air leaks and the regulator is adjusted to 115 psi minimum.

TROUBLESHOOTING GUIDE

Malfunction	Cause	Possible Remedies
The turntable does not rotate in any direction.	1. Power cord not plugged in. 2. Voltage supply low.	1. Plug cord into outlet. 2. Check voltage at outlet.
Insufficient turntable power.	1. Supply voltage low. 2. Loose drive belt.	1. Check voltage, 110V min. 2. Re-tension belt.
Rim clamps do not hold wheel securely.	1. Low air pressure 2. Air regulator not adjusted properly.	1. Check air supply, 115-psi min. 2. Adjust regulator to the minimum air pressure of 115 psi.
The bead-breaker does not have sufficient power to break the bead.	1. Low air pressure. 2. Air regulator not adjusted properly.	1. Check air supply for minimum air pressure. 2. Increase air pressure to 115 psi



NOTE:

Other malfunctions may occur which would be largely technical in nature. Please call a qualified technician or Kwik-Way Products for assistance.

540 TIRE CHANGER

MACHINE DESCRIPTION

See Figure 3

1) PEDAL CONTROLS

Reversing Pedal (A) controls the direction of rotation for the table. Pressing down on the pedal rotates the table in a clockwise rotation, while rising up on the pedal turns the table counter clockwise

Bead Breaker Pedal (B) is used to activate the bead breaker arm. Holding the pedal down activates the arm. You must release the pedal to deactivate the arm.

Wheel Clamp Pedal (C) operates the wheel clamps; pedal down will close the clamps, while the pedal up will open the clamps. The pedal has a détente position, and with a little practice, assists in the control of the opening and closing of the clamps.

Tower Tilt Pedal (D) is used to tilt the tower back for set up and tire removal during operation.

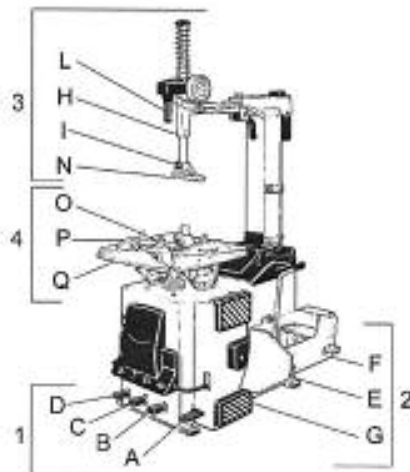

Figure 3

2) BEAD BREAKER ASSEMBLY

Bead Breaker Plate (E) is used to separate the tire bead from the wheel.

Bead Breaker Arm (F) has three positions and can be adjusted to accommodate various width rims.

Bead Breaker Pads (G) support the tire and wheel during the bead breaking operation.

540 TIRE CHANGER

3) COLUMN ASSEMBLY

Sliding Arm (H) slides in and out to accommodate various wheel diameters

Mount/Demount Head (I) with the use of the bead lifting lever, is used to remove the tire and remount the tire to the wheel

Air Lock Handle (L) is rotated to lock the mount, demount head and sliding arm in their work position for mounting and dismounting tires from wheels

Tower Tabs (N) is a nylon insert that protects the wheel from contact with the mount, demount head during bead removal

4) TURNTABLE ASSEMBLY

Rim Clamp Jaws (O) hold the wheel to the table in either internal or external positions.
(See next page for detail)

Rim Clamp Inserts (P) are made from nylon and prevent damage to the wheel during clamping

Tower Telescopic Switch (N/S) is located in the upper left hand corner of the front panel and is used to extend the tower for wider wheel widths.

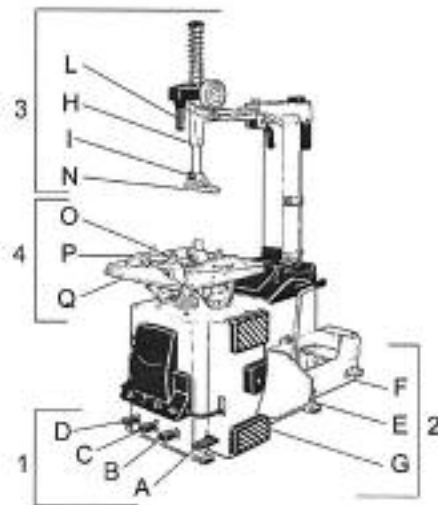

Figure 3

540 TIRE CHANGER

26" Adjustable Jaws

A device that makes it possible to work on tires up to 26" The drawings below illustrate the procedure for changing the position of the 4 tracks. Figure 4

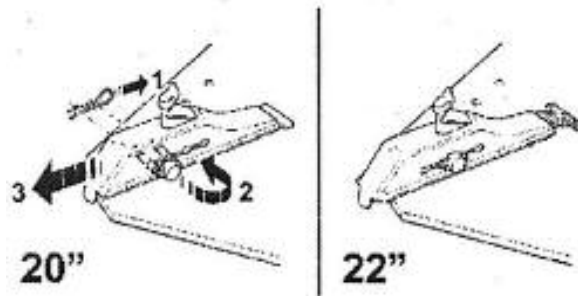
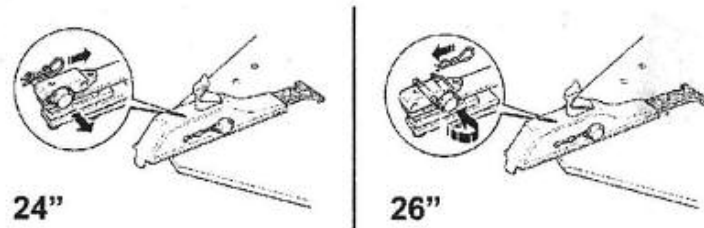

Figure 4



540 TIRE CHANGER

540 ACCESSORIES PROVIDED

Bead Lifting Lever	Part Number 502-1026-83
Tower Tabs (5)	Part Number 502-1007-98
Zeppa Low Profile Tire Assist	Part Number 502-1020-95
Lube Reservoir and Brush	Part Number 502-0013-52

 Always pay careful attention to the WARNING SIGNS shown on adhesives applied to the machine.

If one or more of the warning decals disappears or shows signs of deterioration, you can order a replacement decal from Kwik-Way. Figure 5

Head Decal	Part Number 502-1009-82
Electrical Voltage Decal	Part Number 502-1007-89
Bead-Breaker Decal	Part Number 502-1009-83
Tilt Column" Decal	Part Number 502-1007-76

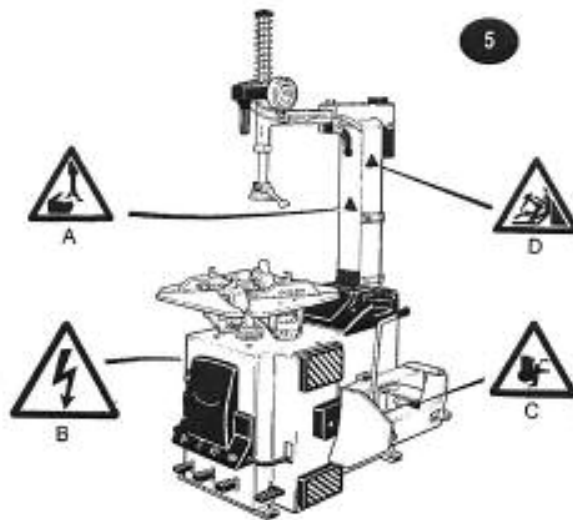

Figure 5

540 TIRE CHANGER

MACHINE OPERATION

PRELIMINARY OPERATIONS

It is highly recommended that you study and familiarize yourself with the nomenclature of the machine before attempting operation.

BEAD-BREAKING Figure 6

In preparation for the bead breaking operation, remove the valve stem core and completely deflate the tire. Remove any wheel weights, which are present.

NOTE: If the tire is being removed for repair, and the assembly is not to be rebalanced, mark the location of the tire to the stem and all weight locations prior to removal. This will provide a reference for remounting the tire and placing the weights at the location from where they were removed.

Figure 6

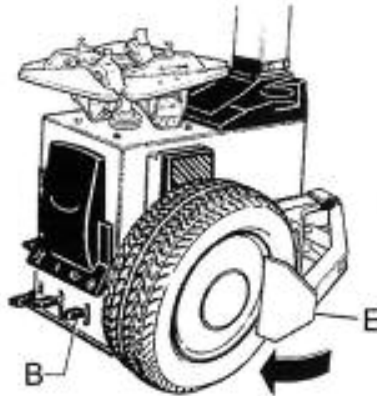

1. Place the wheel assembly against the bead breaker pads and carefully position the breaker blade so as to have the radius of the blade slightly inside the radius of the wheel.
2. Step down on the bead breaker pedal (B) the blade will push the tire bead away from the wheel flange.
3. Repeat the operation at various points around the wheel and on both sides of the wheel.

NOTE: It is highly recommended when breaking beads on alloy or chrome wheels to use the optional bead blade protector PN 502-1018-00 to prevent scratching or other possible damage.



When using the bead-breaking arm take care not to have hands between the tire and the bead-breaker!

540 TIRE CHANGER

MACHINE OPERATION (continued)

DEMOUNTING THE TIRE (Standard Passenger Car / Light Truck Tire and Wheel)

Move the tilt tower to the rear position so as to permit mounting the wheel assembly to the turntable.

NOTE: It is highly recommended to externally clamp all wheels whenever possible, especially alloy or chrome wheels, so as to prevent damage during dismount.

1. Press down on the clamp jaw pedal to expand the jaws.
2. With both beads broken, position the wheel on the clamps and while pressing down on the wheel, step on the pedal and close the jaws. This will lock the assembly to the table.
3. Step down on the tilt tower pedal and move the tower to the forward position so as the mount, demount head is over the wheel. Unlock the sliding arm and move the mount, demount head over and down so that the radius of the head is against the radius of the wheel. For wider wheels, the tower can be telescoped to a higher position using the switch on the front of the base – switch to race position.
4. Lock the slide arm lock so as to hold the position, the head will now move up and back to the correct dismount position. This will permit use of the bead lifting lever without contacting the wheel.

NOTE: Check the tower tab insert to sure it is in place and is in good condition.

5. Insert the bead-lifting lever, positioning the lever in the notch (I) of the mount, demount head. Lift the bead over the demount ramp and slip the lever out. Step down on the table rotation pedal. The turntable will rotate clockwise and remove the upper bead. Figure 7

Figure 7

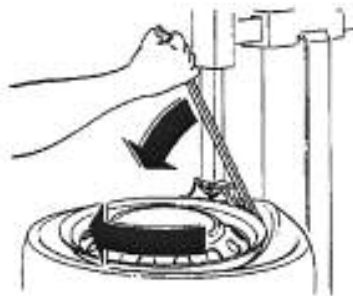

6. Insert the bead lifting lever as described in step 6, so as to remove the lower bead in the same way as above.
7. Step down on the tilt tower pedal to move the tower to the rear then remove the tire

NOTE: A good quality rubber lube should be used while removing the tire from the wheel. It will speed up the operation and prevent bead damage to the tire.



Take care not to insert fingers between tire and rim while the chuck is rotating.

540 TIRE CHANGER

MACHINE OPERATION (continued)

MOUNTING THE TIRE (Standard Passenger Car / Light Truck Tire and Wheel) Figure 8

In preparation for mounting the tire, check the tire and wheel diameters to assure correct size and match. Lubricate both beads thoroughly with the tire lube.

CAUTION: Never attempt to mount a tire without verifying size. The most common mistake is attempting to mount a 16.0" tire and a 16.5" wheel. Personal injury can result from improper mounting.

1. Place the tire on top of the wheel and move the tilt tower forward.
2. The mount demount head will be in the correct position from the initial set up to remount the tire
3. Place the lower bead over the leading edge of the mount demount head (I) and while pushing down on the side wall of the tire, step down on the turn table pedal. Continue to push down on the tire so as to have the lower bead of the tire drop into the drop center of the wheel.
4. Repeat the process for the upper bead.

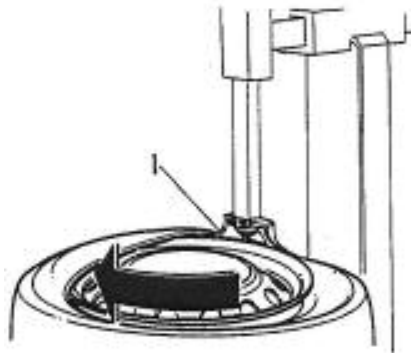

Figure 8

NOTE: See the section on the Tecnoroller III-SL section of the manual for mounting low profile and EMT tires using the Tecnoroller III-SL and Helper Arm

MACHINE OPERATION (continued)

INFLATION PROCESS



WARNING! The inflation process is potentially dangerous. The operator must adopt all the measures necessary in order to guarantee SAFE CONDITIONS

INFLATION SAFETY DEVICE

The machine is fitted with a pressure limiting valve set at 48 PSI and a maximum pressure valve set at 58 PSI. These are designed to protect the operator from potential danger resulting from the inflation of tires on the turntable. Figure 9



WARNING! To inflate tires on the turntable in conditions of "MAXIMUM SAFETY" it is advisable to use the tire retainer safety belt provided.



Figure 9



540 TIRE CHANGER

ROUTINE MAINTENANCE

To insure proper operation of the machine, it is essential to perform periodic maintenance.

MECHANICAL PARTS: Keep the moving parts of the machine clean, wash them with naphtha or a similar product, lubricate them with oil or grease.

LUBRICATOR: Check and maintain the oil level in the lubricator, the level must always be within the min/max listed on the outside.

WATER SEPARATOR: Periodically check and remove any water from the separator.

TURNTALBE DRIVE BELT: Check the belt to see that correct tension is maintained and adjust as required.

INFLATION GAUGE: Periodically check the gauge for function and accuracy.

TECHNICAL ASSISTANCE AND SPARE PARTS

For any malfunctions, consult the Troubleshooting Guide on Page 6 of this manual. Any malfunctions other than those listed should be checked by a qualified technician. For prompt assistance, please have the machine model and serial number ready when you place your call.

Any SPARE PARTS must be ordered from Kwik-Way Products or an authorized distributor the manufacturer denies all responsibility for damage or malfunctions resulting from use of non-original substituted parts.

540 TIRE CHANGER

PART NUMBER REFERENCES (ROUND TABLE)

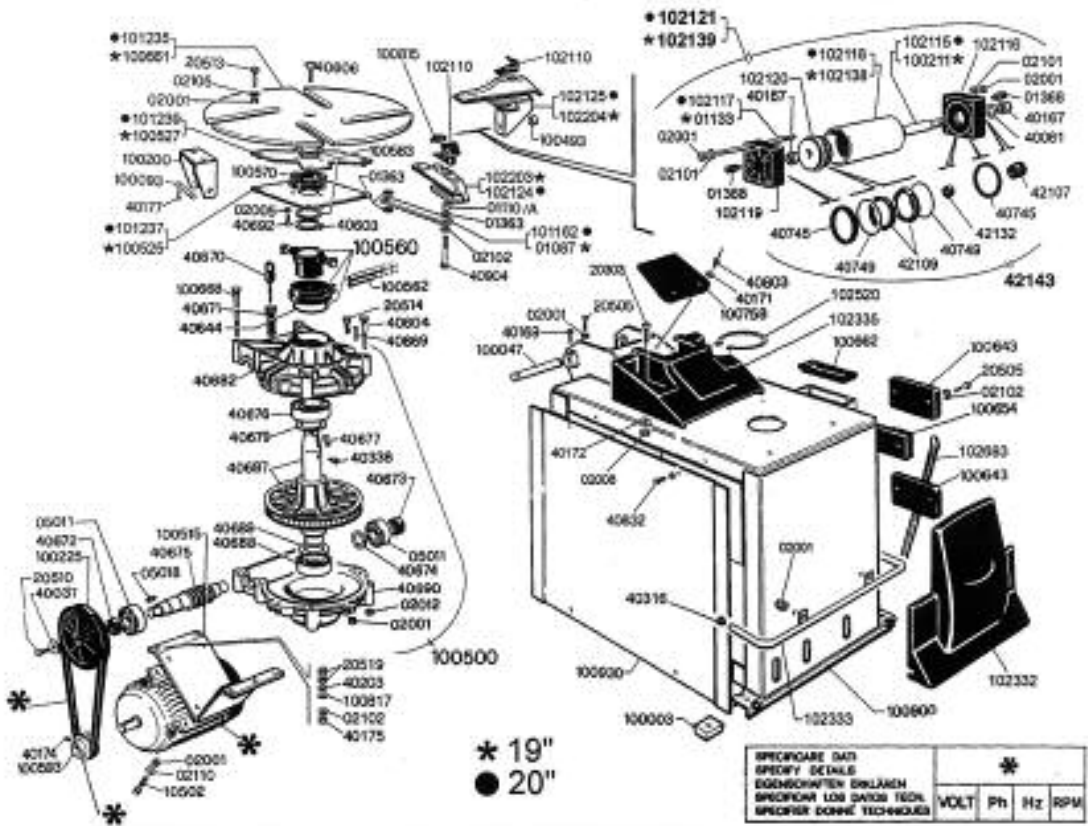

540 TIRE CHANGER

PART NUMBER REFERENCES (SQUARE TABLE)

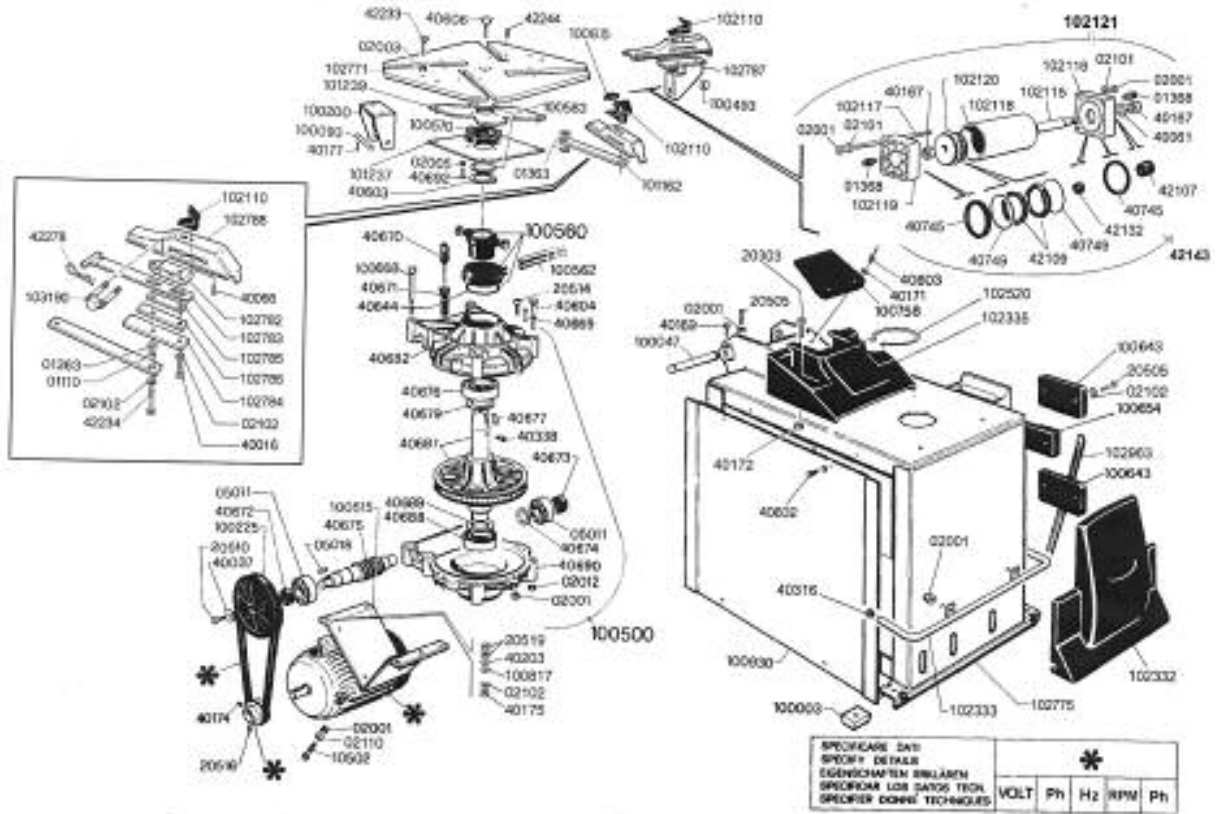

540 TIRE CHANGER

PART NUMBER REFERENCES

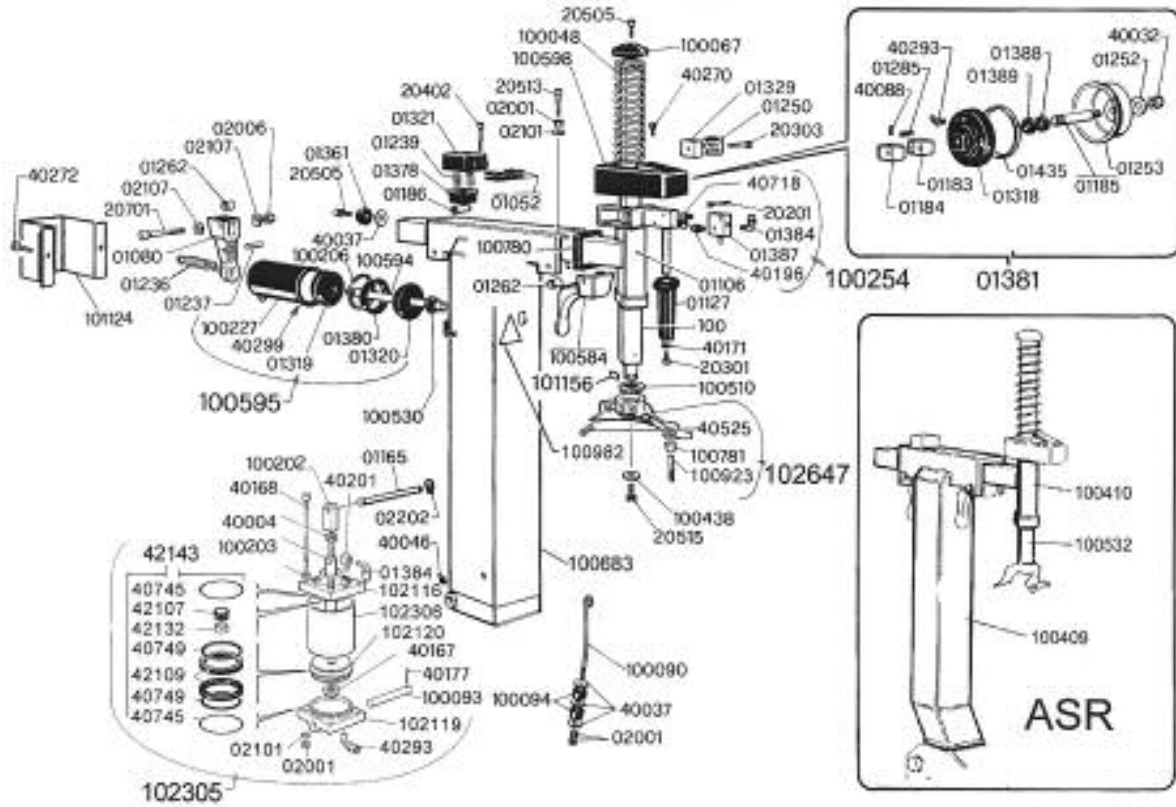

540 TIRE CHANGER

PART NUMBER REFERENCES

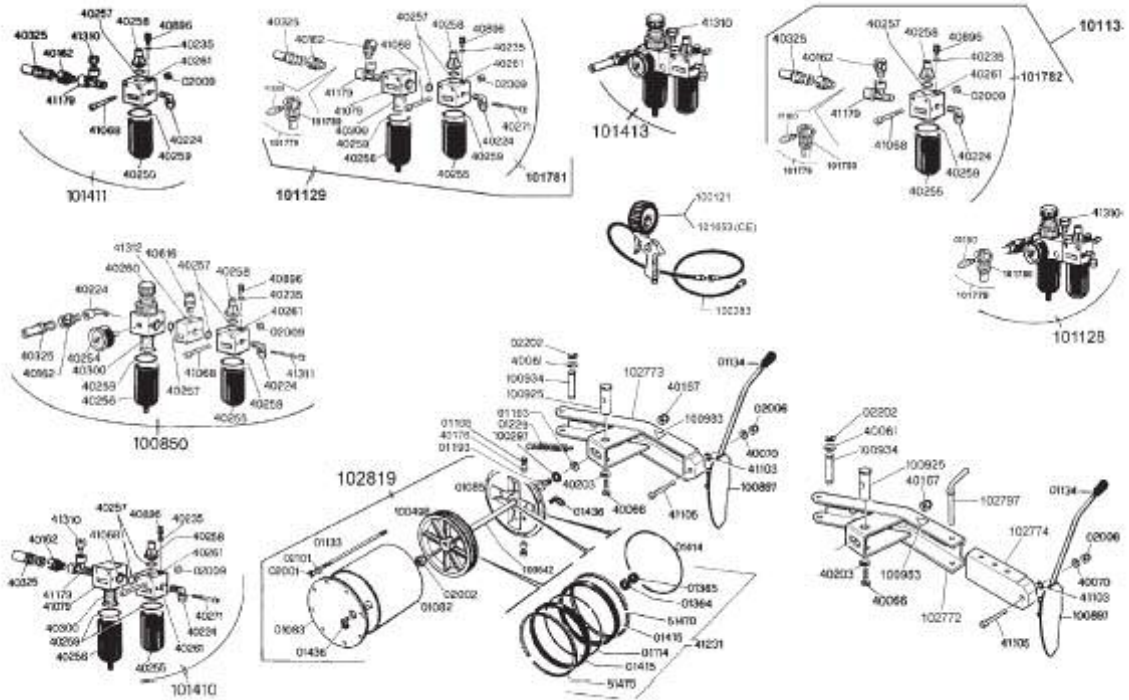

540 TIRE CHANGER

PART NUMBER REFERENCES

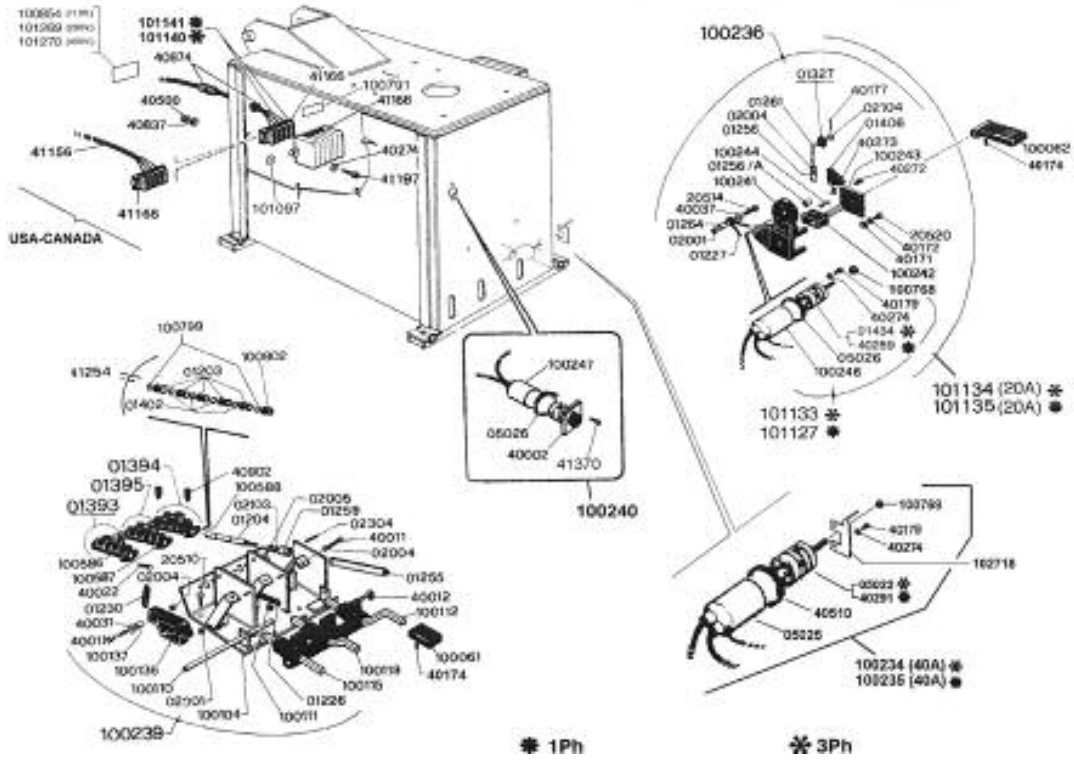

540 TIRE CHANGER

PART NUMBER REFERENCES

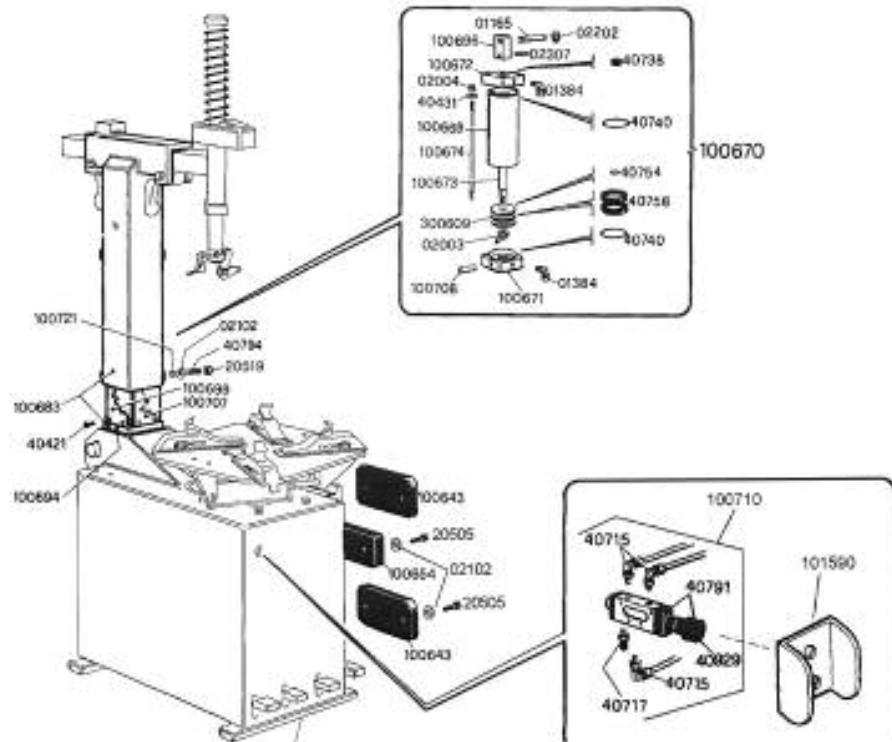

540 TIRE CHANGER

PART NUMBER REFERENCES

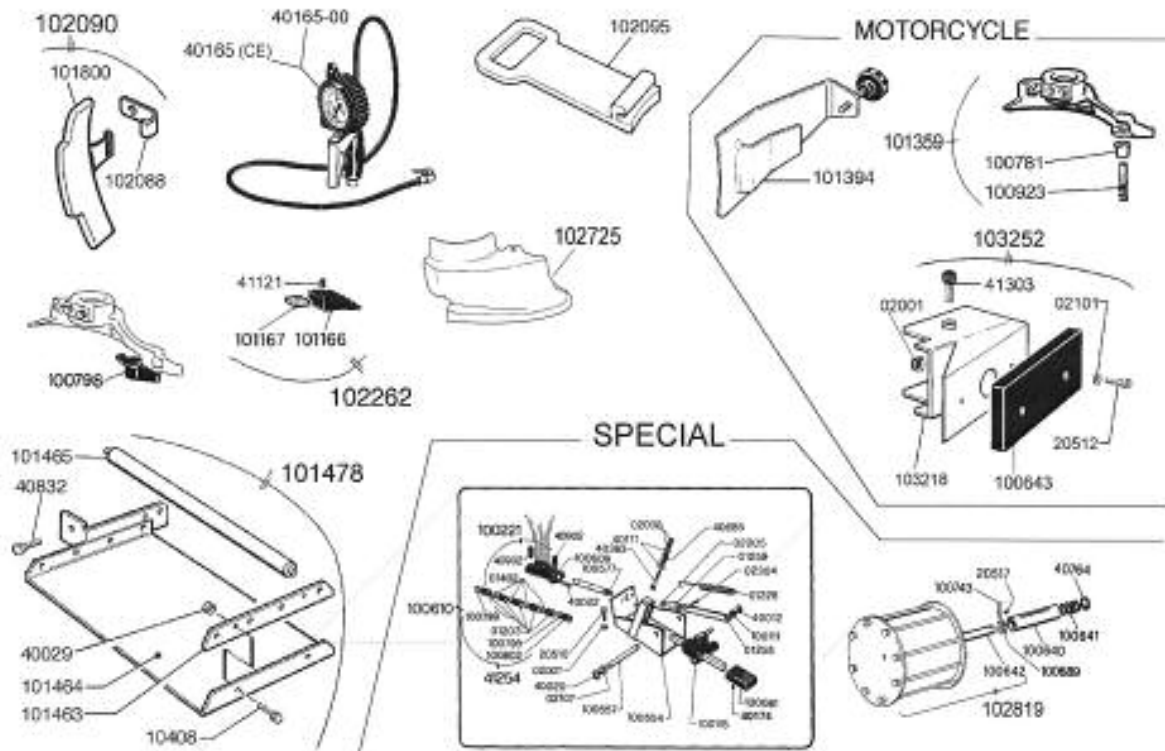

540 TIRE CHANGER

WARNINGS

The present operating manual is an integral part of the product. Carefully study the warnings and instructions contained in it. This information is important for safe use and maintenance. Conserve this booklet carefully for further consultation.

THE MACHINE IS DESIGNED AND CONSTRUCTED TO BE USED FOR THE MOUNTING AND DEMOUNTING OF TIRES FOR CARS AND MOTORCYCLES. THE MACHINE HAS BEEN DESIGNED TO OPERATE WITHIN THE LIMITS DESCRIBED IN THIS MANUAL AND IN ACCORDANCE WITH THE MAKER'S INSTRUCTIONS.

The machine must be used only for the purpose for which it was expressly designed. Any other use is considered wrong and therefore unacceptable.

The maker cannot be held responsible for eventual damage caused by improper, erroneous, or unacceptable use.



This symbol is used in the present manual to warn the operator of particular risks associated with the use of the machine.

540 TIRE CHANGER

TECNOROLLER III-SL

The Tecnoroller III-SL is essential for dismounting and mounting high performance low profile and EMT (run flat) type tires. Please follow the instructions carefully and observe all cautions and safety warnings.

INSTRUCTIONS FOR USE

DISMOUNTING THE TIRE

NOTE: It is highly recommended to externally clamp all alloy and chrome wheels to prevent damage.

1. The insertion of the jaw between the bead of the tire and wheel flange can be difficult. In order to push the wheel down to create the distance required, expand the table jaws to the fully open position. With the jaws pinned in the proper position for the wheel diameter, place the wheel and tire on the table. Now using the large bead roller wheel, position the device as shown in Figure 10. Press down on the air toggle lever in the control panel until the roller is down onto the wheel and then simultaneously close the table jaws.

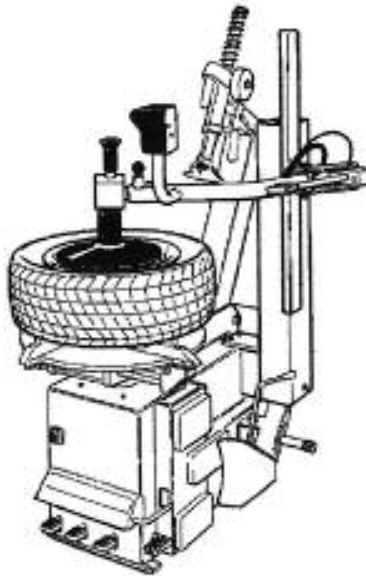

Figure 10

540 TIRE CHANGER

2. Sometimes during the demounting, the lower bead may reseal itself. By using the bead roller wheel as shown in Figure 11, it will not be necessary to remove the wheel in order to repeat the bead breaking operation. To raise the lower bead, manually position the arm so that the bead roller wheel is at the edge of the wheel. While rotating the turntable, raise the bead roller wheel by pushing up on the air toggle lever on the control panel.

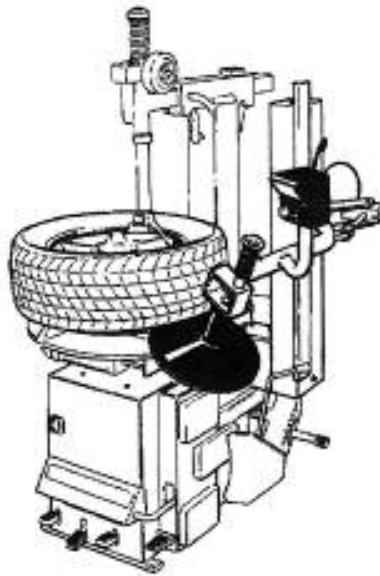

Figure 11

540 TIRE CHANGER

3. Remove the upper bead from the wheel flange by insert the bead-lifting tool as described in the standard tire and wheel dismounting section of the manual. On some low profile tires it may be necessary to use the supplementary roller to assist in this operation. See Figure 12

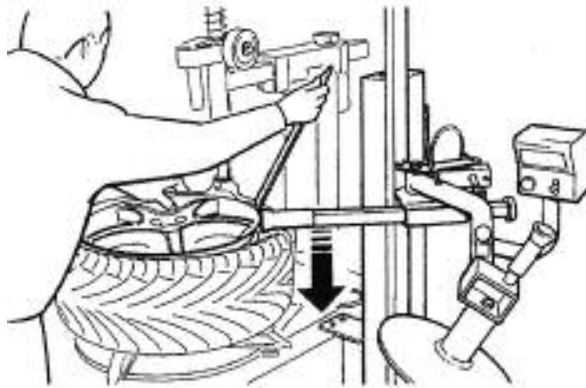

Figure 12

4. Once the upper bead is removed, to remove the tire from the wheel, you can use the supplementary roller as show in Figure 13. Position the roller so that the end of the roller wheel is in contact with the edge of the wheel flange, this establishes the correct diameter position. While holding the tire up, raise the roller and rotate the turntable. The bead will be pushed up over the top wheel flange, thus removing the tire. Have the tilt tower in the rear position to allow for maximum working area.

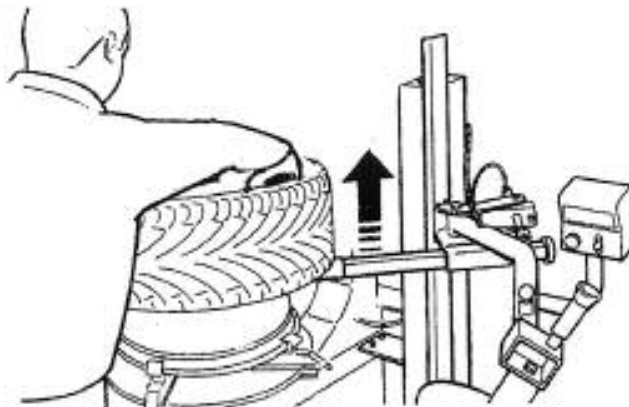
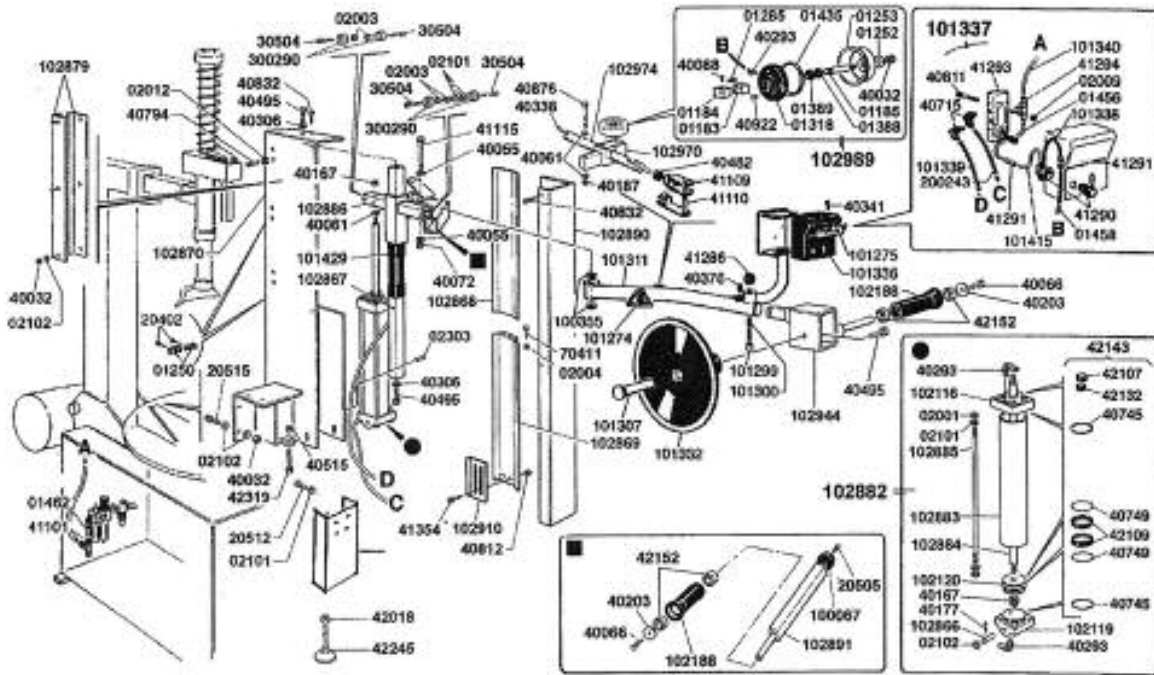

Figure 13

540 TIRE CHANGER

TECNOROLLER III-SL PART NUMBER REFERENCES



540 TIRE CHANGER

FOLLOWER ARM

MOUNTING THE TIRE

NOTE: The Tecnoroller III-SL is fitted with a helper or follower arm, which is designed to help hold the bead into the drop center of the wheel to assist in beading low profile and EMT tires.

1. Install the lower bead onto the wheel following the instructions provided earlier in the remounting section of the manual.
2. Position the supplementary roller on to the tire, with the end of the roller at the wheel flange radius.
3. Position the helper arm on the upper bead just to the right of the supplementary roller. Using the air lever on the Tecnoroller III-SL panel push the lever down and position the bead "just" into the wheel drop center.
4. Step down on the table rotation pedal and carefully rotate the tires, while guiding the upper bead over the mount, demount head. Rotate until the upper bead is installed

CAUTION:

THE FOLLOWER ARM WILL ROTATE WITH THE TIRE, MAKE SURE YOUR HANDS ARE CLEAR OF THE MOVING PARTS.

NOTE: Always use a quality tire lube to assist in the installation of the tire beads.

540 TIRE CHANGER

FOLLOWER ARM PART NUMBER REFERENCES

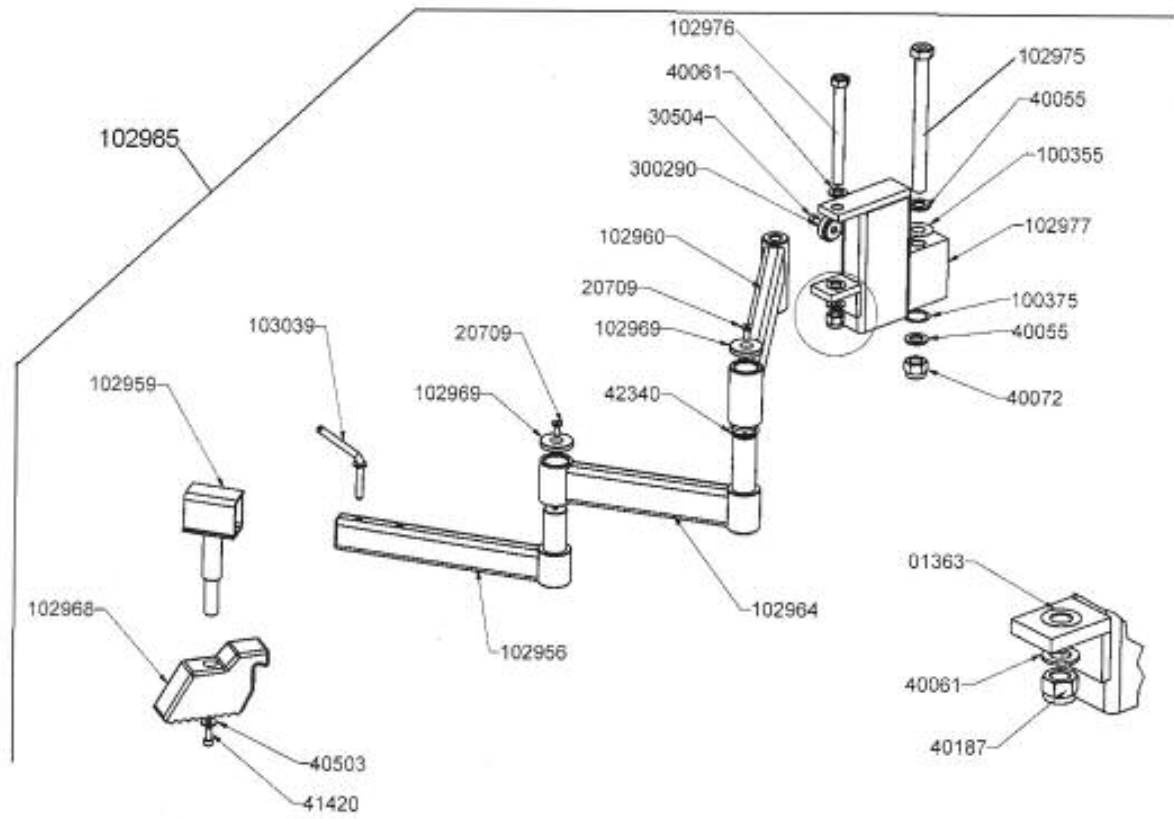

540 TIRE CHANGER

INFLATION DEVICE



WARNING! Carefully study and follow all the warnings and instructions given below.

WARNINGS

1. Carefully check that the rims and tires are not worn or damaged and are of matching sizes.
2. Keep people out of the way during operation.
3. Before inflating the tire, check that there are no wheel weights fitted on the rim.
4. To establish the correct operating pressure for a tire during mounting carefully follow the instructions for use given below and abide by the pressure given by the manufacturer of the vehicle and/or tire in the relevant technical specifications. If this information is not available to the operator it must be requested from the manufacturer of the tire.
5. During inflation, constantly watch the pressure reading on the air inflation gauge used for inflating the tire.
To avoid exceeding the pressure prescribed by the manufacturer of the vehicle and/or tire.
6. During all tire mounting and demounting operations, carefully follow the instructions and warnings of the rim and the manufacturer.

INSTRUCTIONS FOR USE

1. When the tire mounting operations are complete and before starting any inflation operation, check that the rim and tire have not been damaged during the process.
2. The tubeless inflation device must be used for tires that are particularly difficult to bead in and therefore to inflate.
3. Connect the tire inflation hose to the tire valve.
4. Position the outlet of the tubeless inflation kit (Nozzle) (B) in a position directly opposite the inflation valve (A), inserting the outlet between the rim flange and tire bead, resting on the edge of the rim. Figure 14

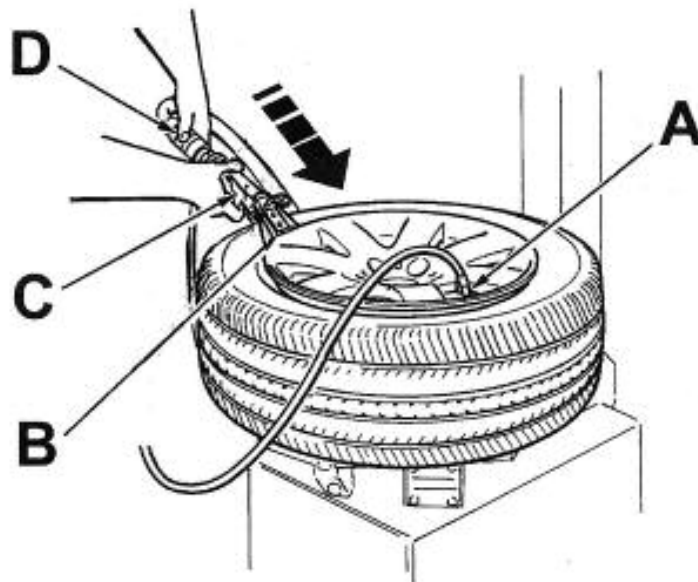

Figure 14

540 TIRE CHANGER

5. Simultaneously activate the inflation pedal and the tubeless inflation kit collar (D) in order to bead in the tire. Ensure that the support of the tubeless inflation kit outlet is held tightly against the rim (C).
6. Repeat the operation until successful, waiting for the cylinder to fill completely.
NOTE: It is essential that the opening of the tubeless inflation kit collar be performed as rapidly as possible so that the sudden release of air in the cylinder impacts against the tire bead causing it to bead to the rim.

Use a quality tire lube to assist in the beading operation.

TROUBLESHOOTING

FAULTS	CAUSES	POSSIBLE SOLUTIONS
The collar does not slide.	<ol style="list-style-type: none">1. The OR is stuck to the valve.2. The return spring is not correctly positioned or is broken.	<ol style="list-style-type: none">1. Try sliding it vigorously. If necessary, disassemble the collar, clean thoroughly, grease and re-assemble.2. Replace the defective spring.
The valve and couplings are leaking air.	<ol style="list-style-type: none">1. The valve is faulty.2. The valve is not correctly attached in is not seating.3. The shutter is jammed.4. The couplings are not tight.5. The connectors were assembled without thread sealant or it is leaking.	<ol style="list-style-type: none">1. Replace the valve.2. Reposition the valve correctly.3. Demount the valve, identify the fault and repair or replace.4. Tighten the connectors or replace if defective.5. Clean thoroughly and replace the sealant.
The device does not bead in the tire.	<ol style="list-style-type: none">2. The tubeless inflation device is not correctly positioned on the wheel.3. The operating pressure is too low.	<ol style="list-style-type: none">1. Check that the device is correctly positioned and that the cylinder is effectively full.2. Increase the operating pressure without exceeding the specified maximum.



WARNING!

In cases of accidental impact of the plastic outlet (the end of the device) from falling or other causes, ensure that there is no obvious structural damage that could compromise correct operation and the safety of the device. Follow the following guidelines:

1. If in doubt, do not use the device.
2. Call a qualified technician or Kwik-Way Products for assistance checking the condition of the tubeless inflation kit.

540 TIRE CHANGER

TUBELESS KIT PART NUMBER REFERENCES

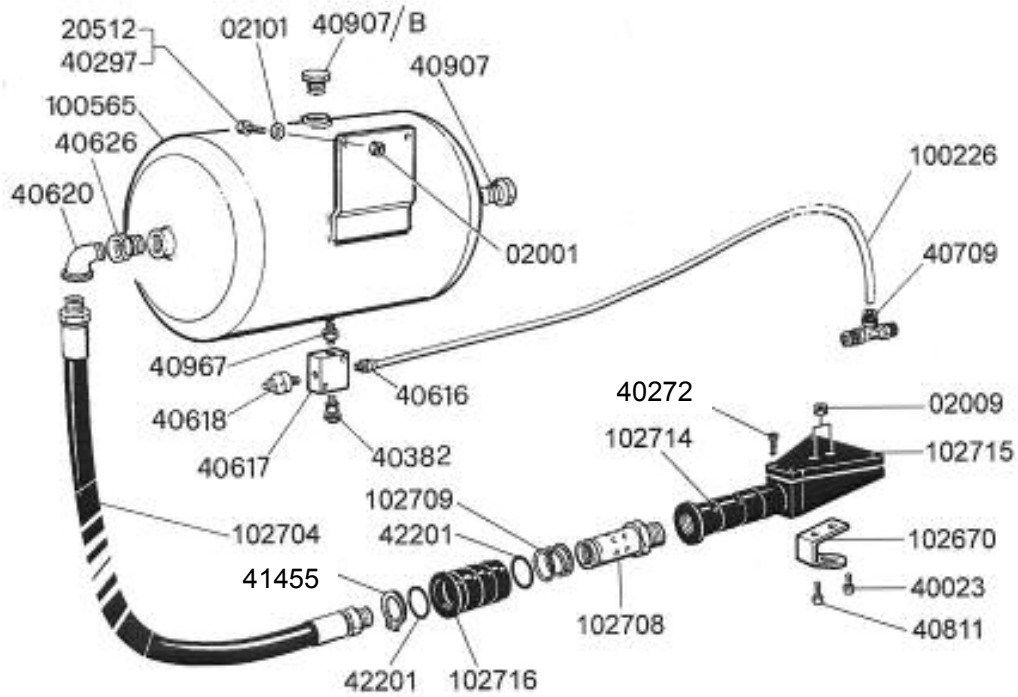

KWIKWAY®

KW Products Inc.

500 57th St., Marion, IA 52302 USA

319/377-9421

319/377-9101 (FAX)

800/553-5953

www.kwik-way.com

service@kwik-way.com