

# GT887A Exploded Drawing

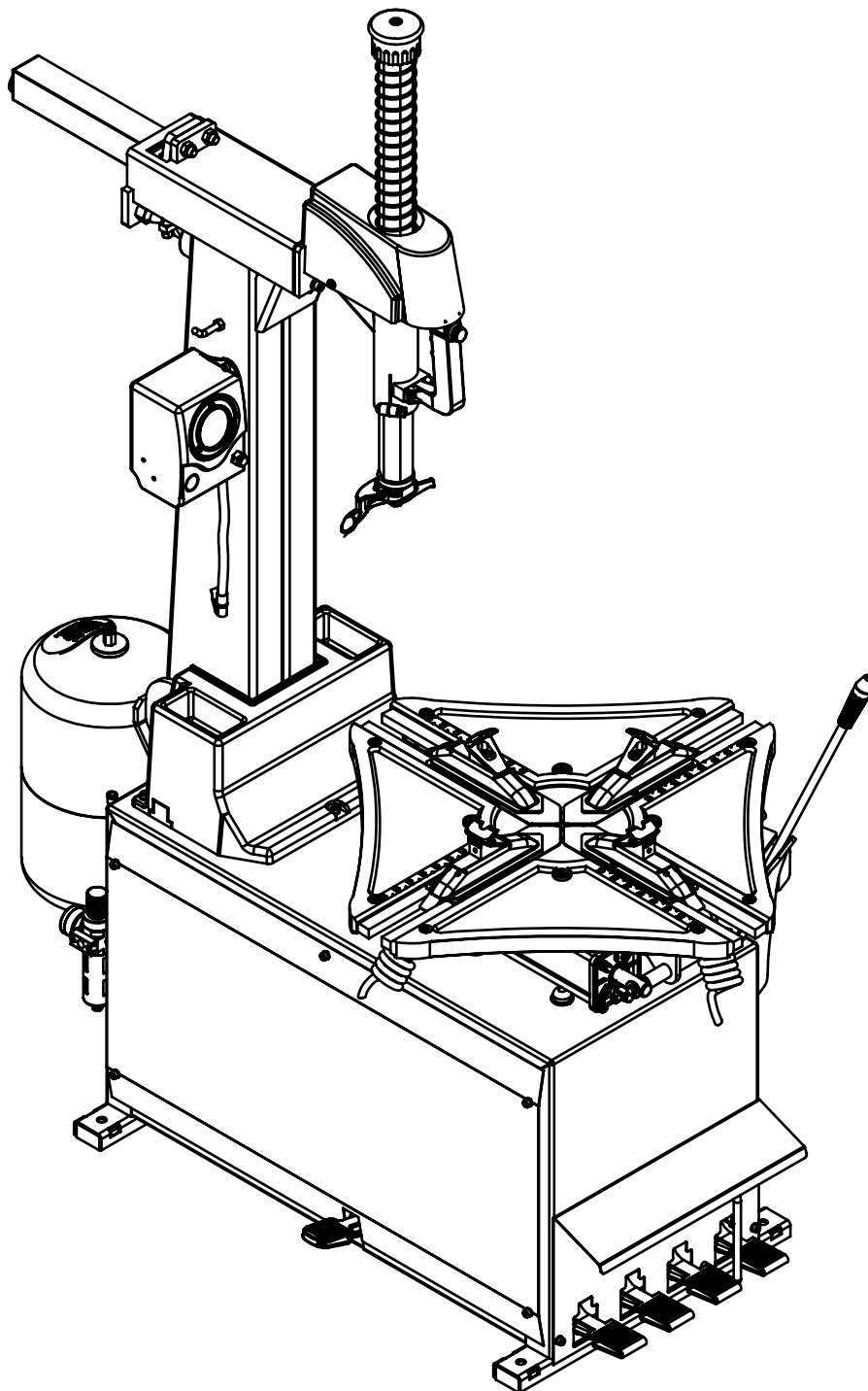

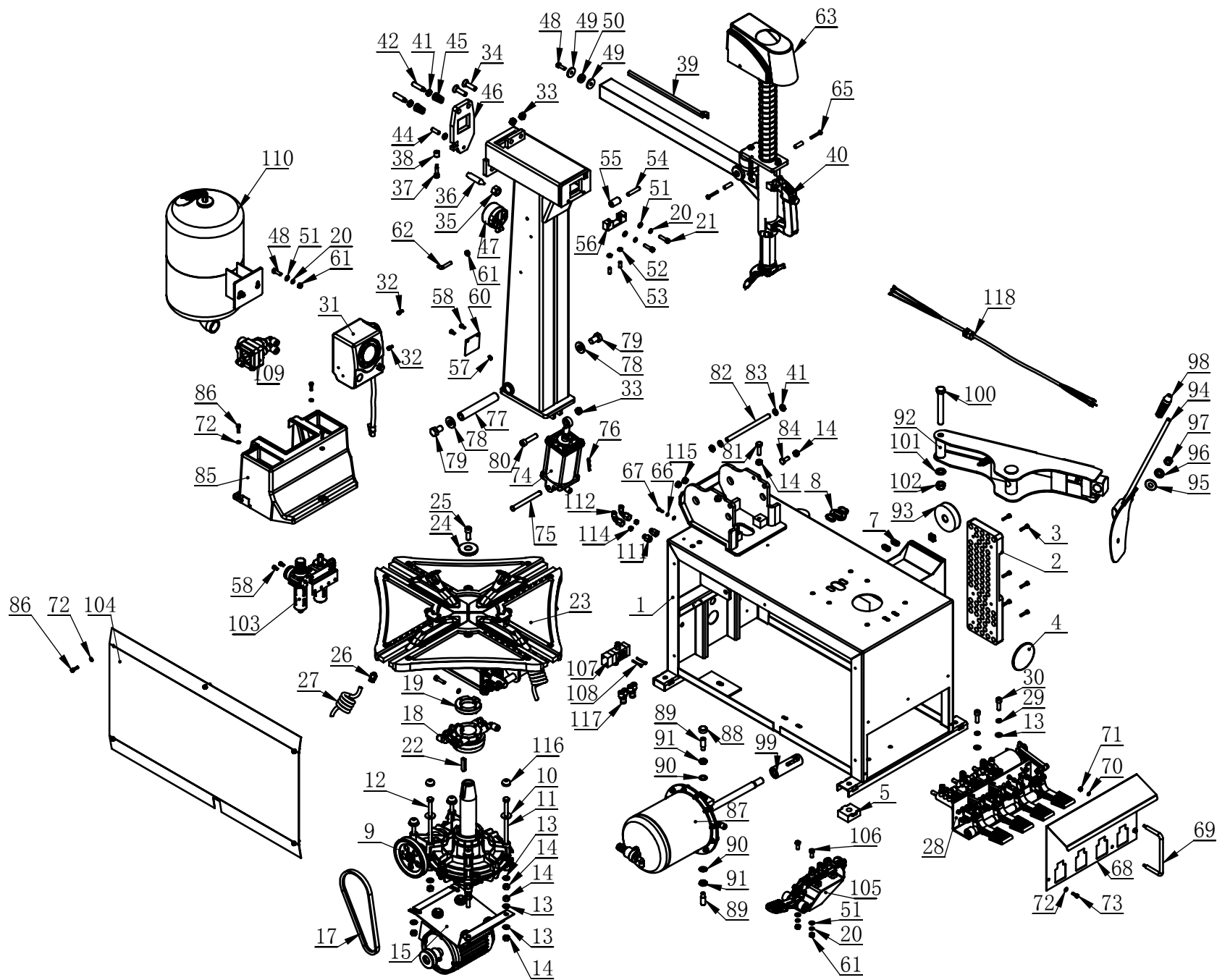

## C-80-1000000

ITEM	PART. No	DESCRIPTION.	QT. Y
1	C-80-1100000	BODY	1
2	C-80-1000001	RUBBER PAD PLATE	1
3	GB70. 1-M6×25	INNER HEXA CYLINDRICAL SCREW	6
4	C-80-1000002	RUBBER PLUG	1
5	C-54-1000005	RUBBER FOOT	4
6	C-54-1000022	PLUG C	2
7	C-54-1000023	PLUG A	2
8	C-54-1000028	PLUG B	1
9	CT-J-4100000	GEARBOX ASSEMBLY	1
10	GB96. 1-10	LARGE WASHER A GRADE	6
11	GB5782-M10×200-8. 8	BOLT M10X200	4
12	GB5782-M10×160-8. 8	BOLT M10X200	2
13	GB95-10	FLAT WASHER	16
14	GB41-M10	HEXANGULAR NUT	18
15	CT-DJ-0334122	MOTOR (380V, 50Hz, 3P, 0. 75Kw)	1
16	C-54-1000015	STOP-UP	1
17	CT-DJ-0000007	BELT (USED WITH 50HZ MOTOR)	1
18	CT-Q-4000000	ROTATING UNION	1
19	CT-Q-6000000	CLAMP RING	1
20	GB93-8	STANDARD SPRING WASHER	7
21	GB70. 1-M8×30	INNER HEXA CYLINDRICAL SCREW	3
22	GB1096-C12×8×45	COMMON FLAT KEY	1
23	CT-Y-5100000	TURNABLE ASSEMBLY	1
24	C-54-1000012	PRESS COVER	1
25	GB70. 1-M12×30	INNER HEXA CYLINDRICAL SCREW	1
26	FPC 10-01	MALE STRAIGHT	4
27	C-54-1000029	PU SPIRAL TUBE	4
28	CT-D-4600000	PEDAL ASSEMBLY	1
29	GB93-10	STANDARD SPRING WASHER	2
30	GB70. 1-M10×30	INNER HEXA CYLINDRICAL SCREW	2
31	CT-K-3400000	INFLATOR COVER ASSEMBLY	1
32	GB70. 1-M6×12	INNER HEXA CYLINDRICAL SCREW	2
33	GB889. 1-M12	1- TYPE PREVAILING TORQUE TYPE HEXAGON LOCK NUT	3
34	GB70. 3-M12×45	INNER COUNTERSUNK SCREW	2
35	GB41-M16	HEXANGULAR NUT	1
36	C-A2-1500011	SCREW	1
37	C-A2-1500012	SCREW	1
38	C-A2-1500008	ROLLER	1
39	C-77-1000009	AIR HOSE CHUTE	1
40	C-80-1300000	HORIZONTAL ARM ASSEMBLY	1
41	GB6172. 1-M12	HEXANGULAR THIN NUT	4
42	GB79-M12×50	INNER HEXA CYLINDRICAL TERMINUS SET SCREW	2
43	GB6172. 1-M10	HEXANGULAR THIN NUT	1
44	GB77-M10×30	INNER HEXA FLAT TERMINUS SET SCREW	1
45	C-80-1000009	PRESS SPRING	2
46	C-80-1000016	SQUARE LOCK PLATE	1
47	C-77-1500000	LOCKING CYLINDER ASSY	1
48	GB5783-M8×25	HEXANGULAR BOLT	3
49	C-77-1000003	CUSHION	2
50	C-77-1000004	RUBBER WASHER	1
51	GB95-8	FLAT WASHER	6
52	GB6172. 1-M8	HEXANGULAR THIN NUT	2
53	GB77-M8×20	INNER HEXA FLAT TERMINUS SET SCREW	2
54	GB119. 1-10×50	CYLINDRICAL PIN	1
55	C-7C-1000005	TELEFLEX	1
56	C-7C-1000004	PEDESTAL	1
57	TC-10-8400006	OIL BOTTLE	1
58	GB70. 1-M6×10	INNER HEXA CYLINDRICAL SCREW	4
59	C-80-1200000A	COLUMN WELDING DRAWING	1
60	C-80-1000010	BLOCK PLATE	1

## C-80-1000000

ITEM	PART. No	DESCRIPTION.	QT. Y
61	GB41-M8	HEXANGULAR NUT	5
62	C-71-1000024	INFLATING GUN HOOK	1
63	C-80-1000007	PROTECTION COVER	1
64	C-77-1000006	PROTECTIVE HOOD LOCK BUSHING	2
65	GB818-M6×40-H	CROSS PANHEAD SCREW	2
66	GB95-5	FLAT WASHER	2
67	GB5783-M5×16	HEXANGULAR BOLT	1
68	C-7C-1000001	PROTECTIVE COVER	1
69	C-71-1000005	PROTECTIVE ROD	1
70	GB93-6	STANDARD SPRING WASHER	2
71	GB41-M6	HEXANGULAR NUT	2
72	GB95-6	FLAT WASHER	13
73	GB70. 1-M6×16	INNER HEXA CYLINDRICAL SCREW	5
74	CT-XD-1000000	PULL-OUT CYLINDER ASSEMBLY	1
75	GB882-12×120	PIN SHAFT	1
76	C-77-1000012	CIRCLIP	1
77	C-80-1000004	ROTATION SHAFT	1
78	C-71-1000010	WASHER	2
79	GB5783-M16×25-W8. 8	HEXANGULAR BOLT	2
80	GB70. 1-M12×50	INNER HEXA CYLINDRICAL SCREW	1
81	GB5783-M10×35	HEXANGULAR BOLT	2
82	C-80-1000003	ROTATION SHAFT	1
83	GB93-12	STANDARD SPRING WASHER	2
84	C-71-1000009	BOLT	2
85	C-80-1000008	PROTECTIVE COVER	1
86	GB70. 1-M6×20	INNER HEXA CYLINDRICAL SCREW	8
87	CT-LS-7400000	BEAD BREAKER CYLINDER ASSEMBLY	1
88	C-54-1000013	SEALED COVER	1
89	C-54-1000010	SCREWS M14X42	2
90	GB861. 1-14	INNER TOOTH LOCK WAHSER	2
91	GB6172. 1-M14	HEXANGULAR THIN NUT	2
92	CT-B-9000000	BEAD BREAKER ARM ASSEMBLY	1
93	C-5B-1000003	RUBBER WASHER	1
94	CT-C-2100000	BEAD BREAKER BLADE	1
95	C-54-1000002	WASHER	1
96	GB955-14	WAVE-FORM SPRING WASHER	1
97	GB889. 1-M14	1-TYPE PREVAILING TORQUE TYPE HEXAGON LOCK NUT	1
98	TC-40-1200022	RUBBER COVER	1
99	C-5B-1400000	LIMIT SET	1
100	GB5782-M16×120	HEXANGULAR BOLT	1
101	GB95-16	FLAT WASHER	1
102	GB889. 1-M16	1-TYPE PREVAILING TORQUE TYPE HEXAGON LOCK NUT	1
103	CT-F-2121200	AIR REGULATOR ASSEMBIY	1
104	C-80-1000006	SIDE PANEL	1
105	CT-K-1D00000	INFLATION PEDAL ASSEMBLY	1
106	GB5783-M8×20	HEXANGULAR BOLT	2
107	C-80-1500000	VALVE	1
108	GB70. 1-M4×35	INNER HEXA CYLINDRICAL SCREW	2
109	CT-K-2200000	QUICK EXHAUST VALVE ASSEMBLY	1
110	CT-K-4100000	STORAGE TANKS ASSEMBLY	1
111	FPC 8-02	MALE STRAIGHT	2
112	FPLF8-02	INSERT ELBOW φ8, R1/4	1
113	FPLF 6-02	FEMALE ELBOW	1
114	C-54-1000027	JOINT SEALING GASKET	2
115	C-71-1000027	HELPER RUBBE PLUG	2
116	C-01-1000006	COVER CAP	6
117	FPY-8	Y-SHAPE INSERT FITTINGΦ8	2
118	CT-E-UN00410	CABLE(3P)	1



## C-80-1300000

ITEM	PART. No	DESCRIPTION.	QT. Y
1	C-80-1310000	HORIZONTAL ARM WELDING	1
2	C-80-1300001	HEXAGON SHAFT	1
3	C-80-1300002	HEXANGULAR LOCK PLATE	1
4	C-71-1330000	HANDLE CONTROLLING VALVE	1
5	C-54-0001000	DEMOUNTING HEAD ASSEMBLY	1
6	C-54-1300008	PRESS WASHER	1
7	C-71-1300005A	POSITIONING BLOCK	1
8	C-54-1300003	VERTICAL SHAFT COVER	1
9	C-54-1300010	VERTICAL SHAFT SPRING	1
10	C-54-1300007	SHOCK ABSORBER WASHER	1
11	C-71-1300004	SPRING	2
12	C-71-1320000	LOCKING CYLINDER ASSY	1
13	GB93-10	STANDARD SPRING WASHER	1
14	GB5783-M10×25-12.9	HEXANGULAR BOLT	1
15	GB70. 1-M6×10	INNER HEXA CYLINDRICAL SCREW	2
16	GB95-8	FLAT WASHER	1
17	GB70. 1-M8×20	INNER HEXA CYLINDRICAL SCREW	1
18	GB70. 1-M10×30	INNER HEXA CYLINDRICAL SCREW	1
19	C-71-1000029	INNER HEXA FLAT TERMINUS SET SCREW	1
20	GB95-4	FLAT WASHER	4
21	GB70. 1-M4×12	INNER HEXA CYLINDRICAL SCREW	4
22	GB6173-M10×1.0	HEXA THIN NUT	1
23	GB889. 1-M10	1-TYPE PREVAILING TORQUE TYPE HEXAGON LOCK NUT	1
24	GB889. 1-M8	1-TYPE PREVAILING TORQUE TYPE HEXAGON LOCK NUT	1
25	GB70. 2-M8×35	INNER HEXA CYLINDRICAL ROUND HEAD SCREW	1

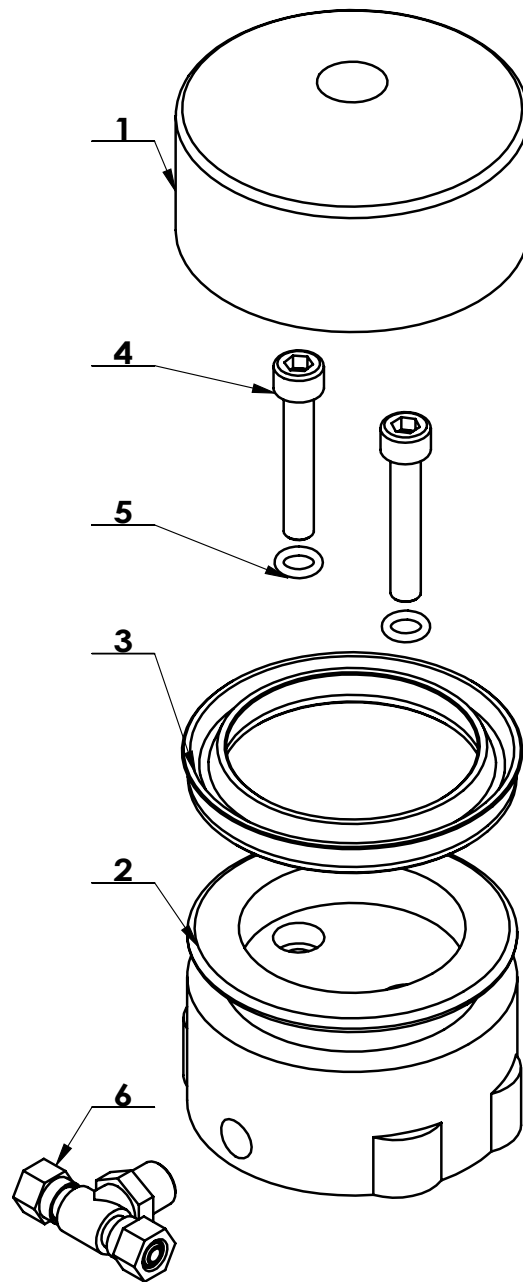

ITEM	PART. No	DESCRIPTION.	QT. Y
1	C-71-1320001	LOCK TURNTABLE CYLINDER HEAD	1
2	C-71-1320002	LOCK CYLINDER BODY	1
3	C-71-1320003	Y-RING	1
4	GB70.1-M6×35	SCREW M6X35	2
5	GB3452.1-6×1.8-G	HYDRAULIC-PNEUMATIC RUBBER O-RING G TYPE	2
6	PBS 6-01	MALE BRANCH TEE NUT	1

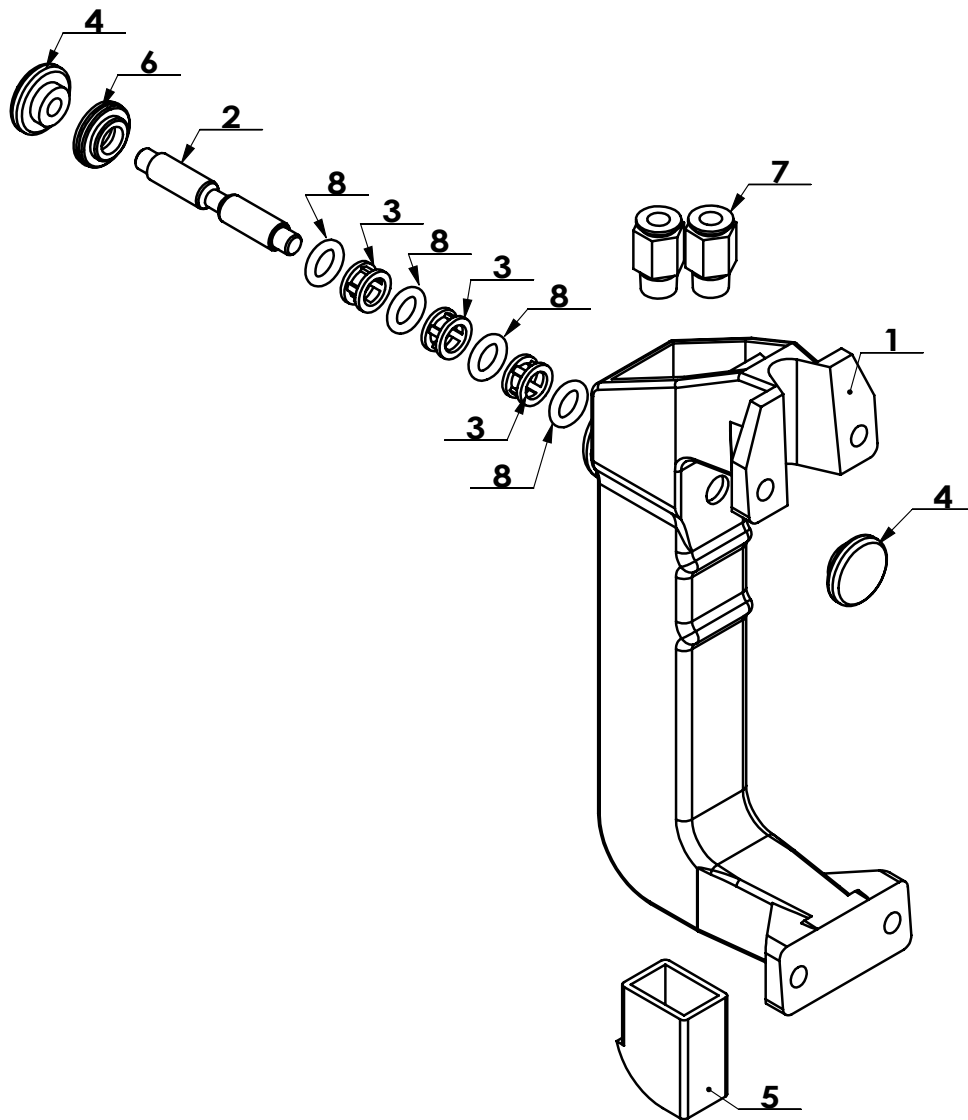

ITEM	PART. No	DESCRIPTION.	QT. Y
1	C-71-1330001	HANDLE CONTROL VALVE	1
2	C-71-1330002	VALVE ROD	1
3	C-71-1330003	VALVE SPACER	3
4	C-71-1330004	FRONT COVER	2
5	C-71-1330005	REAR COVER	1
6	C-71-1330006	FRONT SEALING COVER	1
7	FPC 6-01	MALE STRAIGHT	2
8	GB3452.1-8×2.65-A	HYDRAULIC-PNEUMATIC RUBBER O-RING A TYPE	4



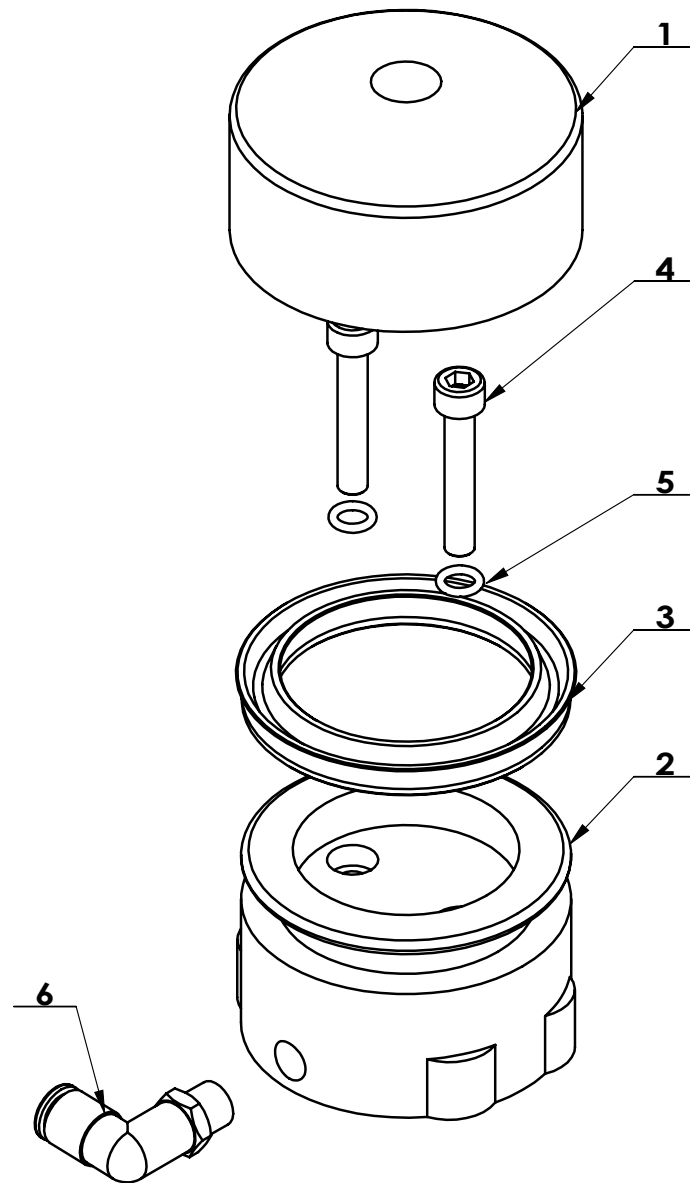

ITEM	PART. No	DESCRIPTION.	QT. Y
1	C-71-1320001	LOCK TURNTABLE CYLINDER HEAD	1
2	C-71-1320002	LOCK CYLINDER BODY	1
3	C-71-1320003	Y-RING	1
4	GB70. 1-M6×35	SCREW M6X35	2
5	GB3452. 1-6×1.8-G	HYDRAULIC-PNEUMATIC RUBBER O-RING G TYPE	2
6	FPL 6-01	MALE ELBOW	1

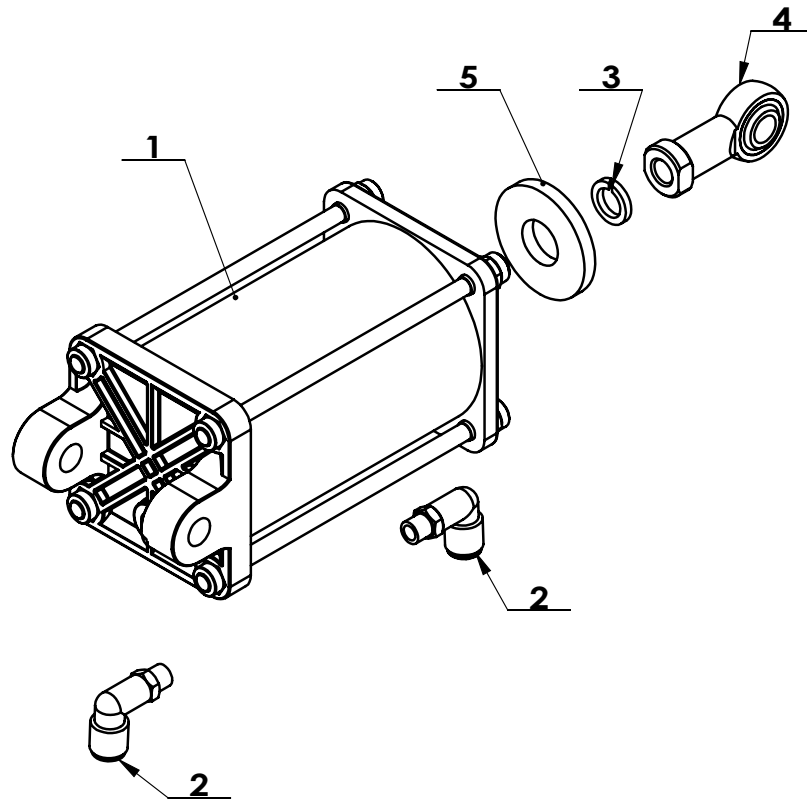

ITEM	PART. No	DESCRIPTION.	QT. Y
1	CT-XD-1100000	PULL-OUT CYLINDER	1
2	FPL 8-01	INSERT ELBOW $\Phi 8$ , R1/8	2
3	GB93-12	STANDARD SPRING WASHER	1
4	CT-XD-1000007	BEARING JOINTS	1
5	H-12-1000001	FELT WASHER	1

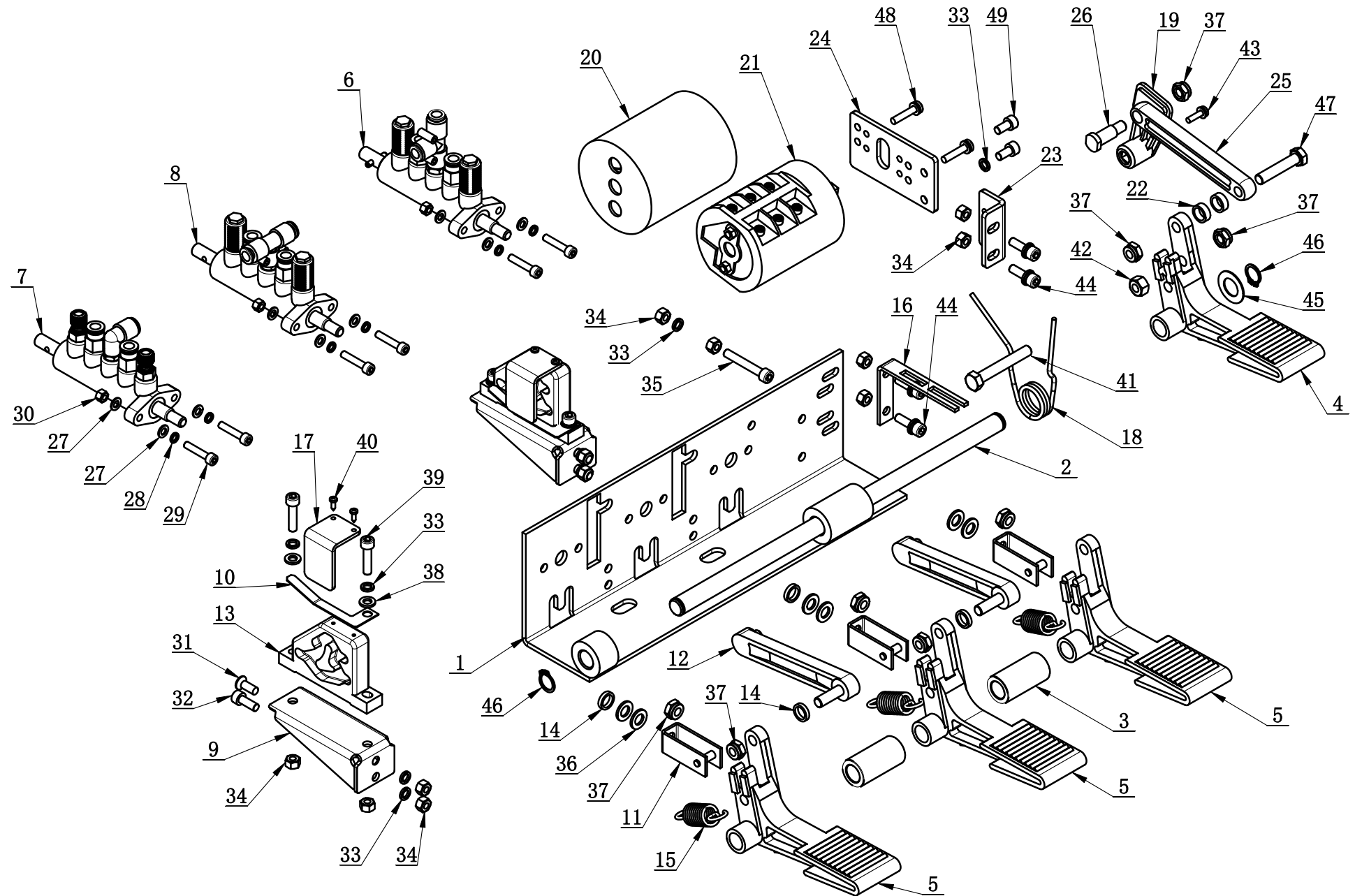

ITEM	PART. No	DESCRIPTION.	QT. Y
1	CT-D-4110000	PEDAL SUPPORT WELDING	1
2	CT-D-4100001	BOTTOM SHAFT	1
3	CT-D-2100001	SPACER	2
4	CT-D-2100006	PEDAL	1
5	CT-D-2100007	PEDAL	3
6	CT-D-0004000	VALVE	1
7	CT-D-0009000	VALVE	1
8	CT-D-0008000	VALVE	1
9	CT-D-2120000	CAM BRACKET WELDING	2
10	CT-D-2100004	FORK SPRING PLATE	2
11	CT-D-2130000	BRACKET RIVETING	3
12	CT-D-1100008	CAM CONNECTING ROD	2
13	CT-D-1100009	CAM	2
14	CT-D-1100016	SPACER	4
15	CT-D-2100003	SPRING	3
16	CT-D-2100010	TORSION SPRING BRACKET	1
17	CT-D-1100011	CAM BAFFLE PLATE	2
18	CT-D-2100002	TORSION SPRING	1
19	CT-D-1100010	REVERSE LEVER	1
20	CT-D-1100014	SWITCH COVER	1
21	CT-D-1100018	SWITCH	1
22	CT-D-2100005	SPACER	2
23	CT-D-5100008	SWITCH SUPPORT	1
24	CT-D-5100009A	SWITCH SUPPORT	1
25	CT-D-2100011	CONNECTION ROD	1
26	CT-D-2100012	ROTATION SHAFT	1
27	GB95-5	FLAT WASHER	12
28	GB93-5	STANDARD SPRING WASHER	6
29	GB70. 1-M5×25	INNER HEXA CYLINDRICAL SCREW	6
30	GB41-M5	HEXANGULAR NUT	6
31	GB819. 1-M6×16-H	CROSS COUNTERSUNK SCREW STEEL 4. 8 GRADE	2
32	GB70. 1-M6×16	INNER HEXA CYLINDRICAL SCREW	2
33	GB93-6	STANDARD SPRING WASHER	10
34	GB41-M6	HEXANGULAR NUT	14
35	GB70. 1-M6×40	INNER HEXA CYLINDRICAL SCREW	1
36	GB95-8	FLAT WASHER	6
37	GB889. 1-M8	1-TYPE PREVAILING TORQUE TYPE HEXAGON LOCK NUT	8
38	GB95-6	FLAT WASHER	4
39	GB70. 1-M6×25	INNER HEXA CYLINDRICAL SCREW	4
40	GB845-ST2. 9×9. 5 H C	CROSS PANHEAD TAPPING SCREW	4

CT-D-4600000

ITEM	PART. No	DESCRIPTION.	QT. Y
41	GB5782-M8×55	HEXANGULAR BOLT	1
42	GB41-M8	HEXANGULAR NUT	1
43	GB9074. 4-M4×16	COMBINATION SCREW	1
44	GB9074-M6×20	COMBINATION SCREW	4
45	CT-D-2100014	WASHER	1
46	GB894. 1-14	SHAFT ELATIC BIG RETAINING RING A-TYPE	2
47	GB5783-M8×40	HEXANGULAR BOLT	1
48	GB9074. 4-M5×25	COMBINATION SCREW	2
49	GB70. 1-M6×12	INNER HEXA CYLINDRICAL SCREW	2

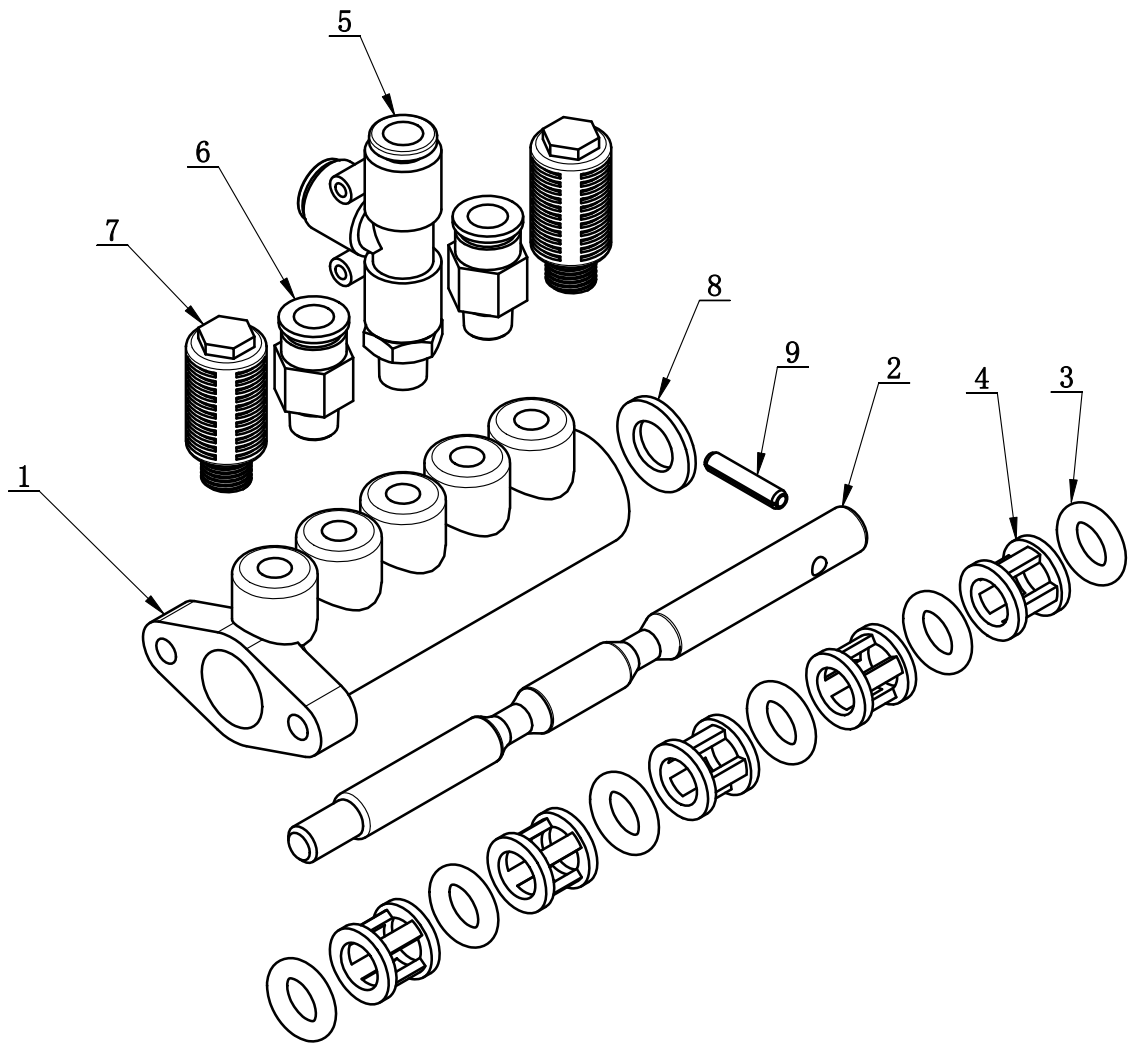

ITEM	PART. No	DESCRIPTION.	QT. Y
1	CT-D-2140002	VALVE BODY	1
2	CT-D-2140001	VALVE STEM	1
3	CT-D-1110003	O-RING	6
4	CT-D-1110004	SPACER	5
5	FPD 8-01	MALE RUN TEE	1
6	FPC 8-01	MALE STRAIGHT	2
7	FSK 01	PLASTIC PARTICLE SILENCER	2
8	GB95-10	FLAT WASHER	1
9	GB879. 1-4×20	ELASTIC CYLINDRICAL PIN, HEAVY	1

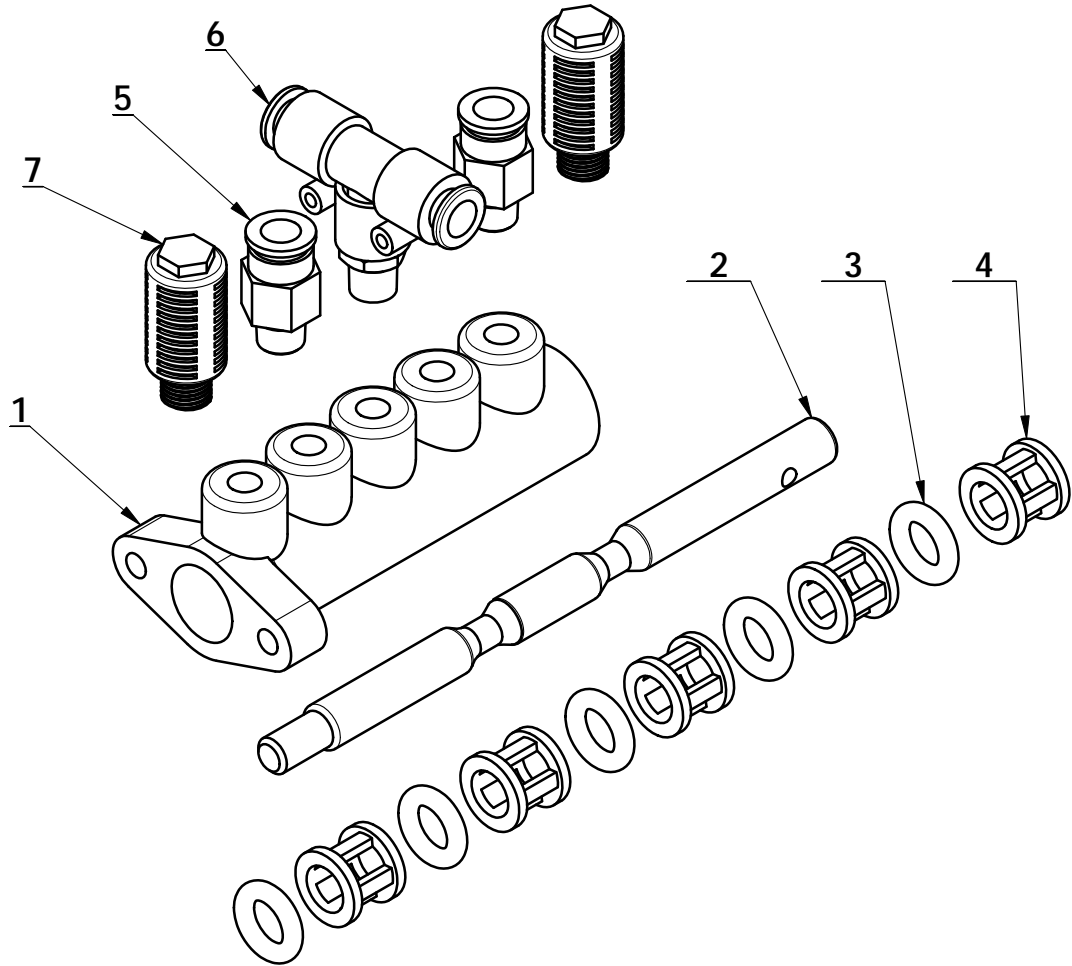

ITEM	PART. No	DESCRIPTION.	QT. Y
1	CT-D-2140002	VALVE BODY	1
2	CT-D-2140001	VALVE STEM	1
3	CT-D-1110003	O-RING	6
4	CT-D-1110004	SPACER	5
5	FPC 8-01	MALE STRAIGHT	2
6	FPB 8-01	MALE BRANCH TEE	1
7	FSK 01	PLASTIC PARTICLE SILENCER	2

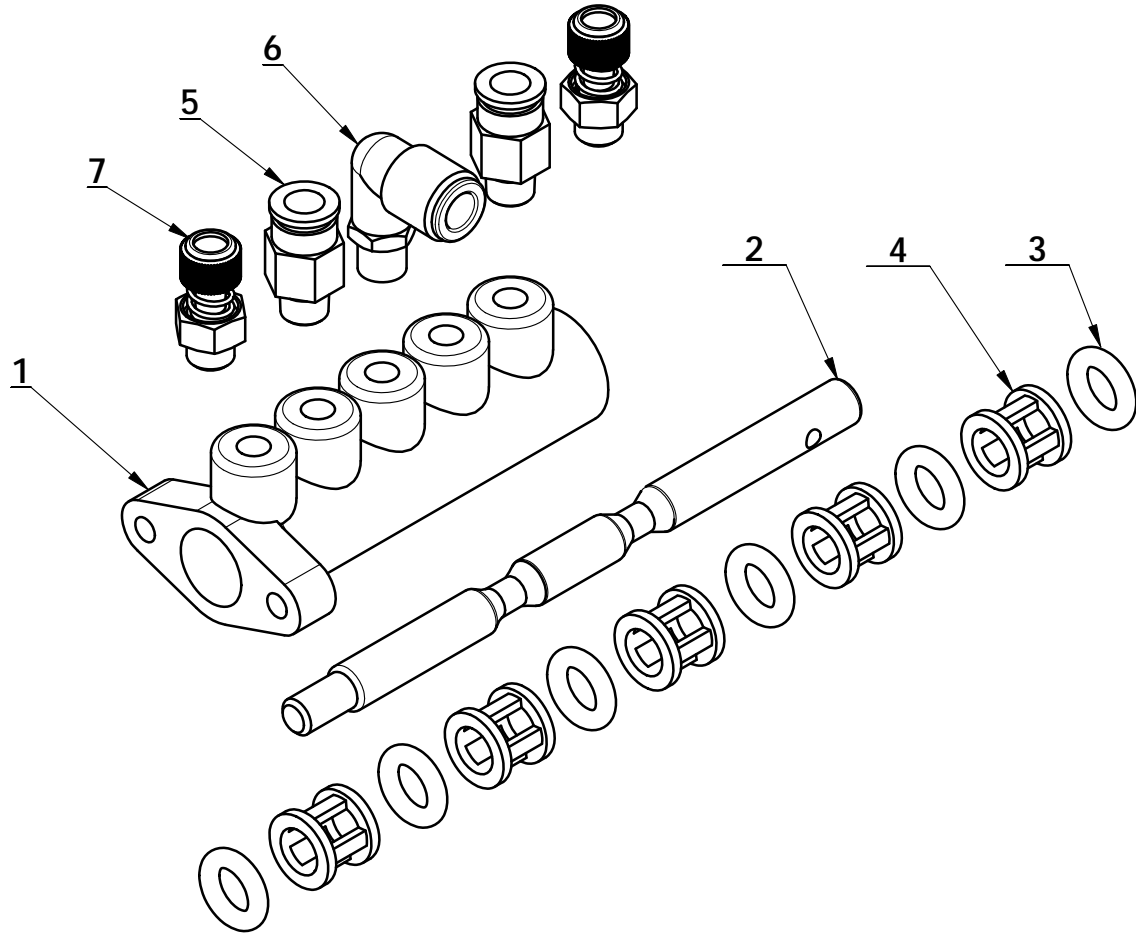

ITEM	PART. No	DESCRIPTION.	QT. Y
1	CT-D-2140002	VALVE BODY	1
2	CT-D-2140001	VALVE STEM	1
3	CT-D-1110003	O-RING	6
4	CT-D-1110004	SPACER	5
5	FPC 8-01	MALE STRAIGHT	2
6	FPL 8-01	INSERT ELBOW $\Phi 8$ , R1/8	1
7	FJSR 01	BRASS REGULATOR SILENCER	2



CT-B-9000000

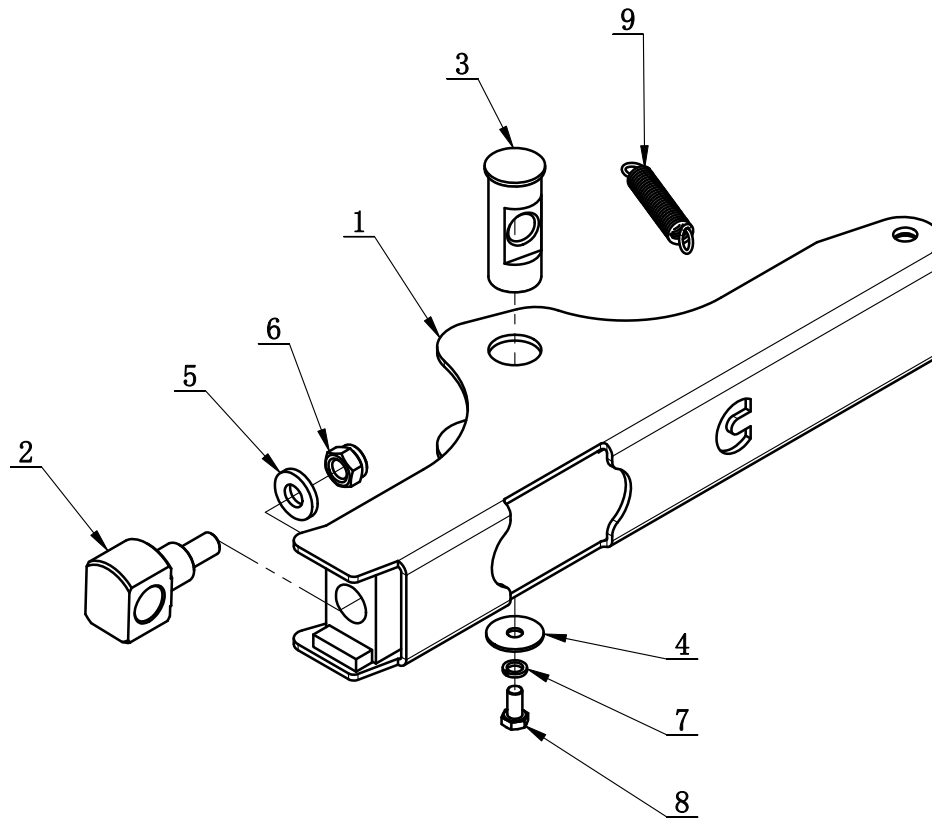

ITEM	PART. No	DESCRIPTION.	QT. Y
1	CT-B-9100000	BEAD BREAKER ARM	1
2	CT-B-9000001	TURN ROD	1
3	CT-B-6000001	CONNECT ROD	1
4	CT-B-6000003	PAD	1
5	C-71-1000010	WASHER	1
6	GB889.1-M16	1-TYPE PREVAILING TORQUE TYPE HEXAGON LOCK NUT	1
7	GB93-10	STANDARD SPRING WASHER	1
8	GB5783-M10×20	HEXANGULAR BOLT	1
9	CT-B-2000002	SPRING	1

CT-LS-7400000

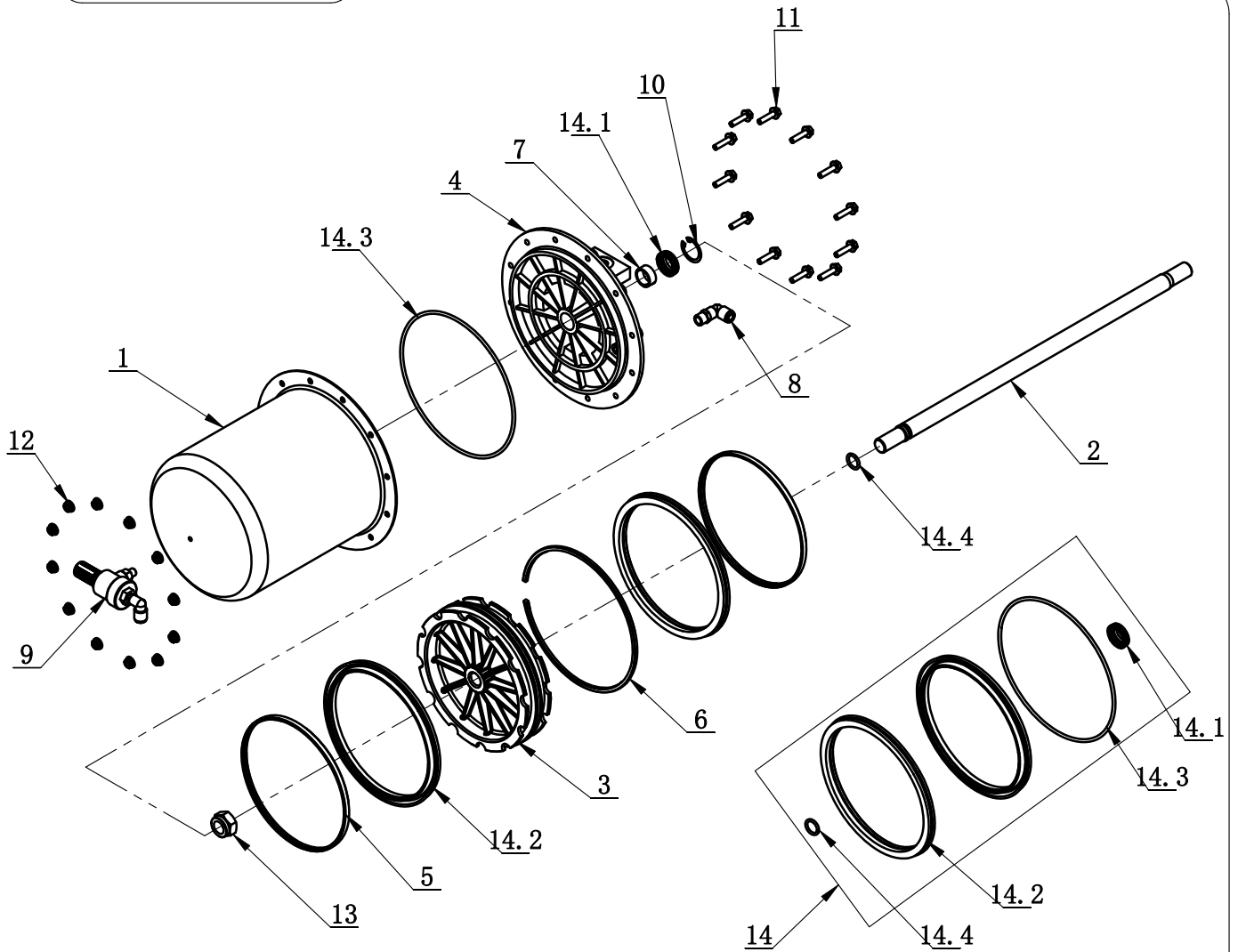

ITEM	PART. No	DESCRIPTION.	QT. Y
1	CT-LS-1100002	CYLINDER BODY	1
2	CT-LS-7100001	CYLINDER PISTON ROD	1
3	CT-LS-1100003	PISTON	1
4	CT-LS-1100004	CYLINDER COVER	1
5	CT-LS-1100006	CLAMP RING	2
6	CT-LS-1100007	PISTION SUPPORT RING	1
7	CT-LS-1100008	GUIDER SPACER	1
8	FPL 8-02	INSERT ELBOW $\Phi 8$ , R1/4	1
9	CT-LS-1320000	QUICK DEFLATE VALVE ON BODY	1
10	GB893. 2-30	ELASTIC RETAINING RING B-TYPE	1
11	GB5789-AM6×25	HEXA FLANGE BOLT	12
12	GB6177. 1-M6	HEXA FLANGE NUT	12
13	GB889. 2-M18×1. 5	NUT M18×1. 5	1
14	CT-LS-1110000	CYCLINDER SEALING PARTS ASSEMBLY	1
14. 1	CT-Y-0160007	SEAL-ROD, CYLNDR	1
14. 2	CT-LS-1100009	Y-RING	2
14. 3	GB3452. 1-185×3. 55-G	O-RING G TYPE	1
14. 4	GB3452. 1-15. 5×2. 65-G	HYDRAULIC-PNEUMATIC RUBBER O-RING G TYPE	1

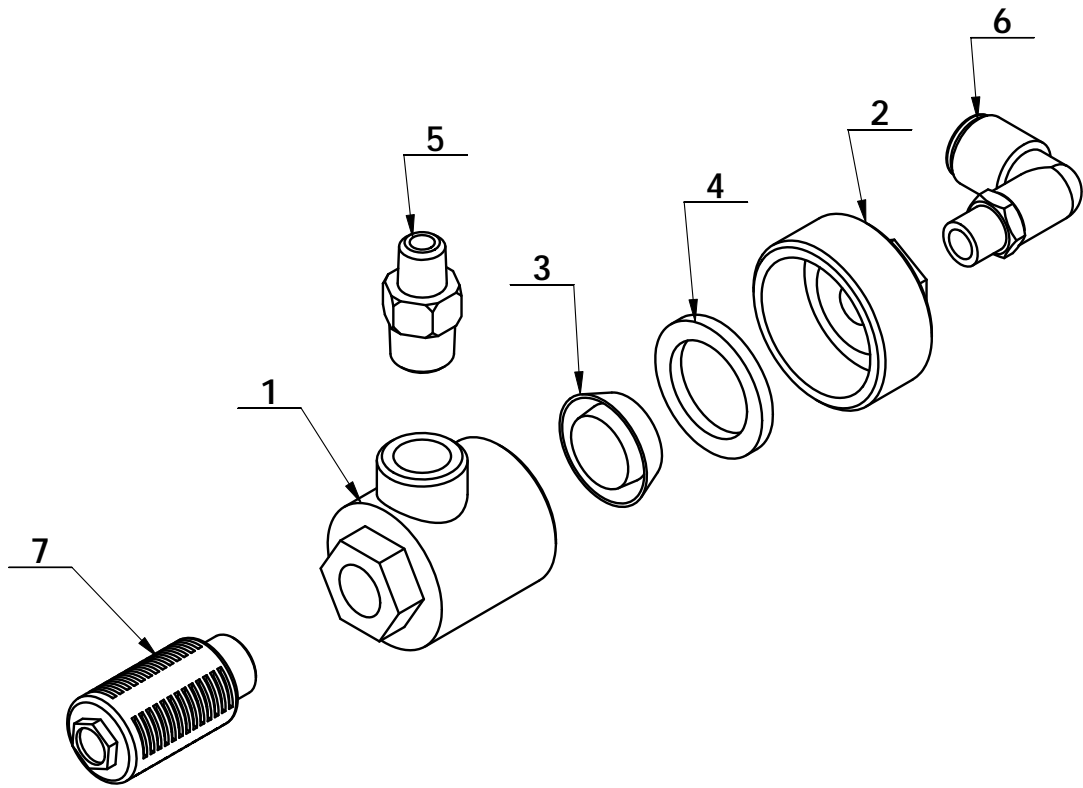

ITEM	PART. No	DESCRIPTION.	QT. Y
1	CT-LS-1310001	LOWER COVER OF QUICK DEFLATE VALVE	1
2	CT-LS-1310002	COVER OF QUICK DEFLATE VALVE	1
3	CT-LS-1310003	PISTON	1
4	CT-LS-1310004	RUBBER WASHER	1
5	CT-K-1100007	FITTING	1
6	FPL 8-01	INSERT ELBOW $\Phi 8$ , R1/8	1
7	FSK 02	PLASTIC PARTICLE SILENCER	1

C-5B-1400000

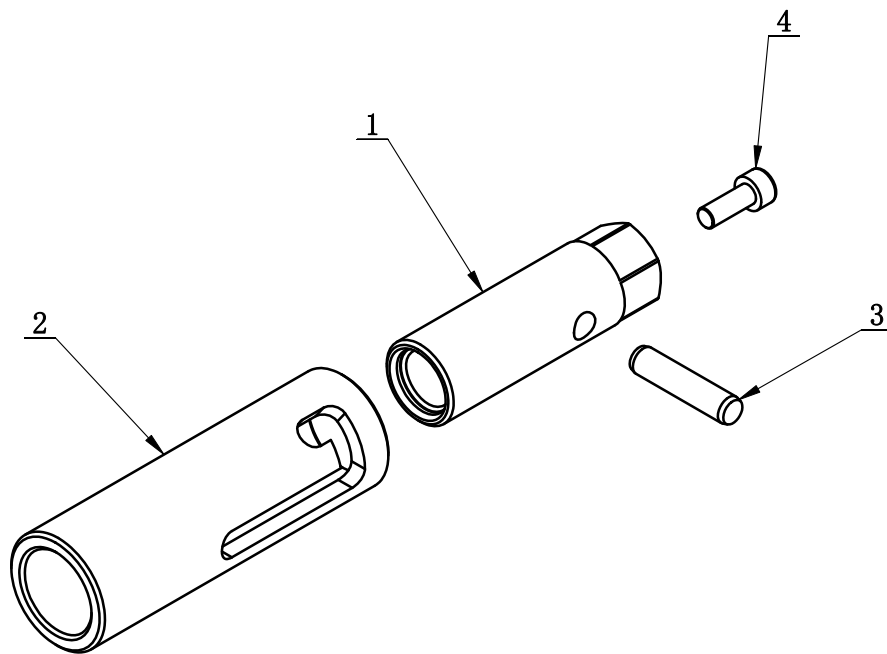

ITEM	PART. No	DESCRIPTION.	QT. Y
1	C-5B-1400001	FIXED AXIS	1
2	C-5B-1400002	REGULATE	1
3	GB119. 1-8×35	CYLINDRICAL PIN	1
4	GB70. 1-M6×16	INNER HEXA CYLINDRICAL SCREW	1

CT-Y-5100000

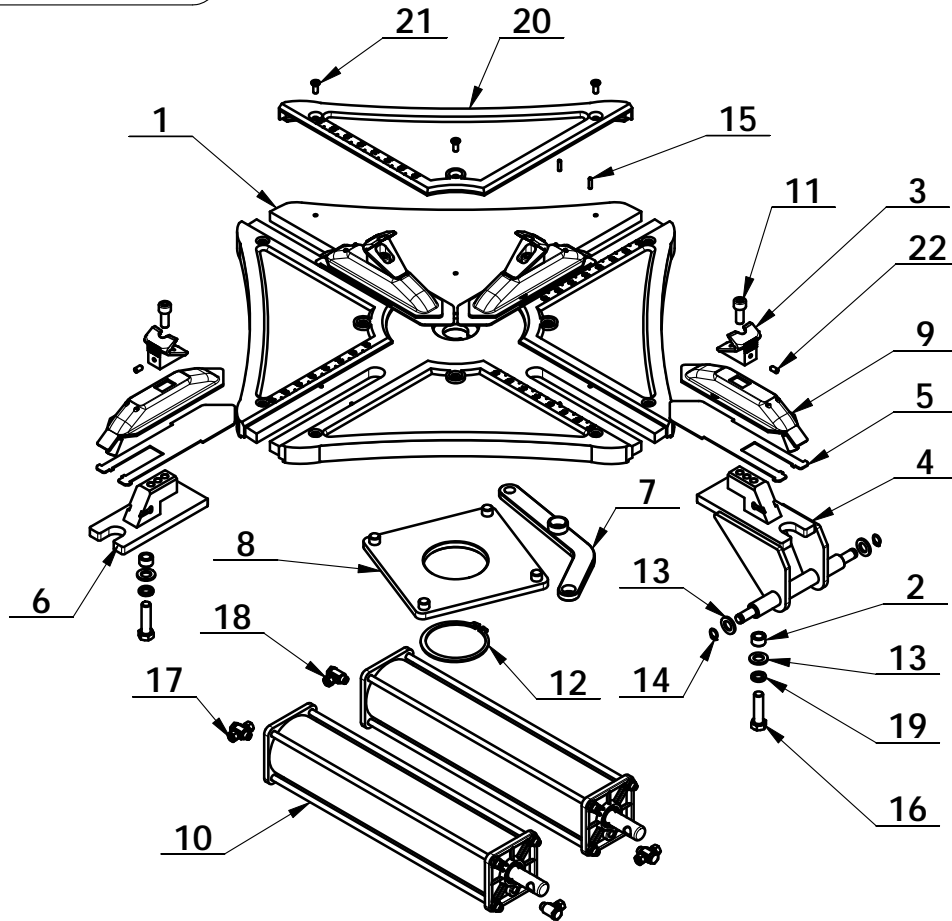

ITEM	PART. No	DESCRIPTION.	QT. Y
1	CT-Y-5040000	TURNTABLE	1
2	CT-Y-0100003	SPACER	4
3	CT-Y-5000002	CLAMP	4
4	CT-Y-5070000	CYLINDER BRACKET	2
5	CT-Y-5000004	WEARABLE WASHER	4
6	CT-Y-5080000	PRESS PLATE WELDING	2
7	CT-Y-5020000	CONNECTION PLATE	4
8	CT-Y-5030000	SQUARE TURNTABLE	1
9	CT-Y-5120000	SLIDE COVER	4
10	CT-Y-5010000	CYLINDER ASSEMBLY D80X350	2
11	GB70. 1-M10×25-12. 9	INNER HEXA CYLINDRICAL SCREW	4
12	GB894. 1-85	SHAFT ELATIC BIG RETAINING RING A-TYPE	1
13	GB95-12	FLAT WASHER	8
14	GB894. 1-12	SHAFT ELATIC BIG RETAINING RING A-TYPE	4
15	GB879. 1-4×16	ELASTIC CYLINDRICAL PIN, HEAVY	8
16	GB5782-M12×45-W8. 8	HEXANGULAR BOLT	4
17	CT-Y-0100008	HINGE ELBOW $\Phi 8$ G1/8	2
18	CT-Y-0100006	HINGE ELBOW $\Phi 8$ G1/8	2
19	GB93-12	STANDARD SPRING WASHER	4
20	CT-Y-5000005	PROTECTIVE COVER	4
21	GB70. 3-M6×16	INNER COUNTER SUNK SCREW	12
22	GB78-M6×12	INNER HEXA CONIC TERMINUS SET SCREW	4

CT-Y-5010000

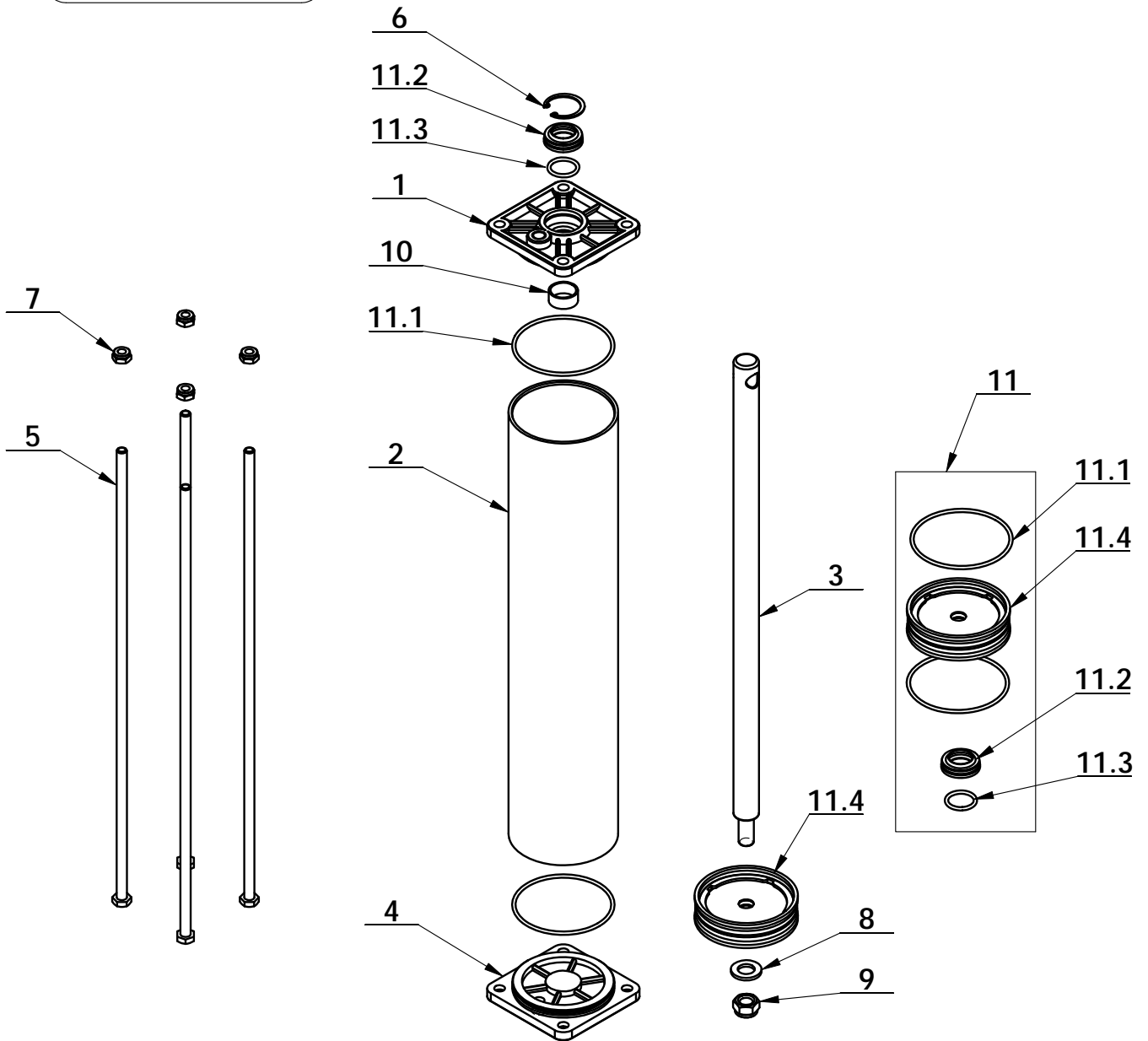

ITEM	PART. No	DESCRIPTION.	QT. Y
1	CT-Y-4120004	CYLINDER FRONT COVER	1
2	CT-Y-5010001	CYLINDER 80MM	1
3	CT-Y-5010002	SHAFT-CLYDR	1
4	CT-Y-4120005	CAP-BASE, CYLNDR	1
5	CT-Y-5010003	BOLT	4
6	GB893. 1-30	ELASTIC RETAINING RING A-TYPE	1
7	GB889. 1-M8	1-TYPE PREVAILING TORQUE TYPE HEXAGON LOCK NUT	4
8	GB95-12	FLAT WASHER	1
9	GB889. 1-M12	1- TYPE PREVAILING TORQUE TYPE HEXAGON LOCK NUT	1
10	JH1 2010	BEARING-SLIDE	1
11	CT-Y-4121000	CYLINDER SEALING PARTS ASSEMBLY	1
11. 1	GB3452. 1-75×2. 65	HYDRAULIC-PNEUMATIC RUBBER O-RING G TYPE	2
11. 2	CT-Y-0160007	SEAL-ROD, CYLNDR	1
11. 3	GB3452. 1-20×2. 65	HYDRAULIC-PNEUMATIC RUBBER O-RING G TYPE	1
11. 4	CT-Y-4120006	PISTON	1

CT-Q-4000000

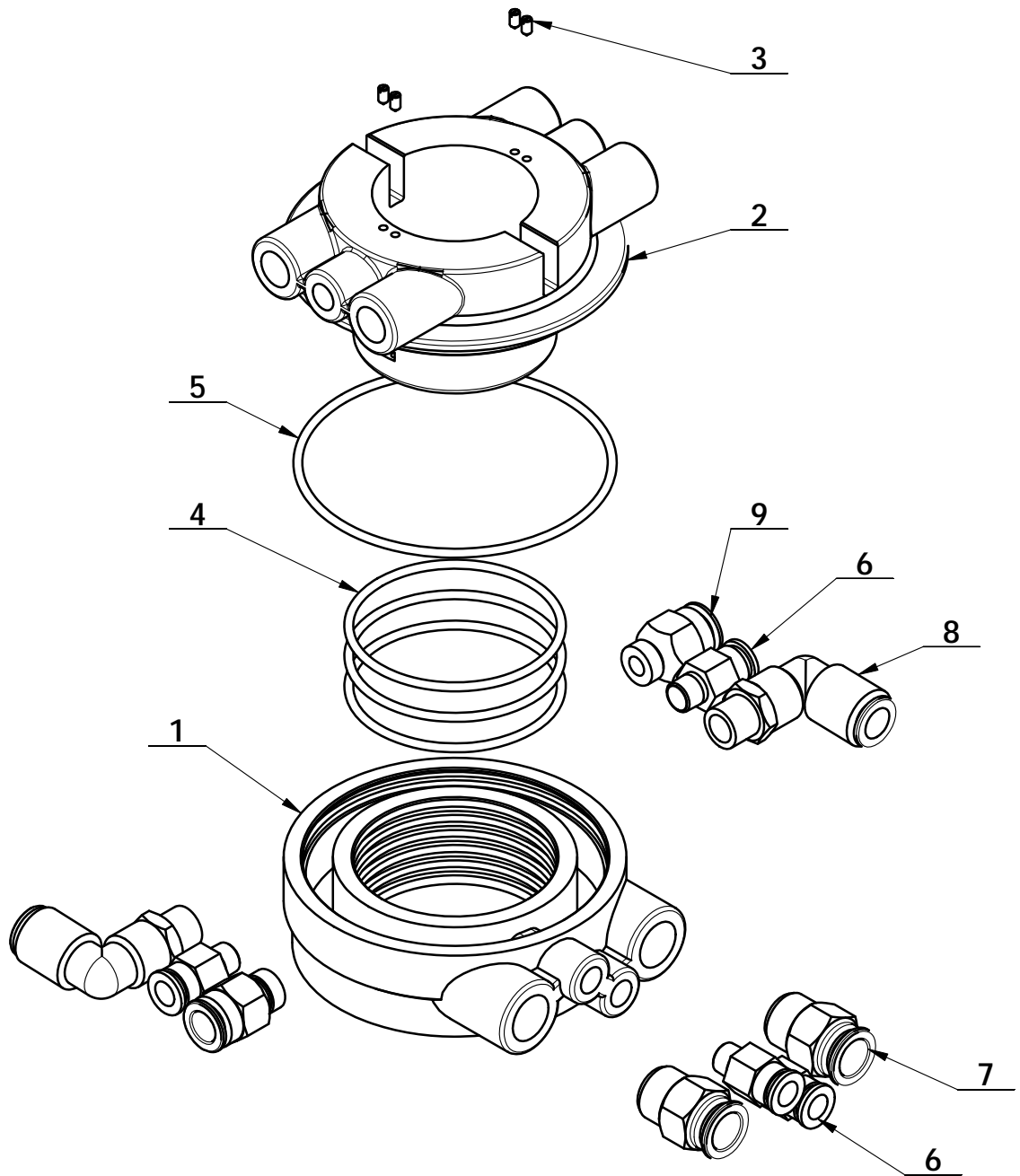

ITEM	PART. No	DESCRIPTION.	QT. Y
1	CT-Q-2000001	FIXED BODY OF AIR GUIDE	1
2	CT-Q-2000002	ROTATING BODY OF AIR GUIDER	1
3	GB71-M3×6	SLOTTED CONIC HEAD SET SCREW	4
4	GB3452. 1-60×2. 65-G	HYDRAULIC-PNEUMATIC RUBBER O-RING G TYPE	3
5	GB3452. 1-90×2. 65-G	HYDRAULIC-PNEUMATIC RUBBER O-RING G TYPE	1
6	FPC 8-01	MALE STRAIGHT	4
7	FPC 12-03	MALE STRAIGHT	2
8	FPL 10-02	MALE ELBOW	2
9	FPC 10-02	MALE STRAIGHT	2

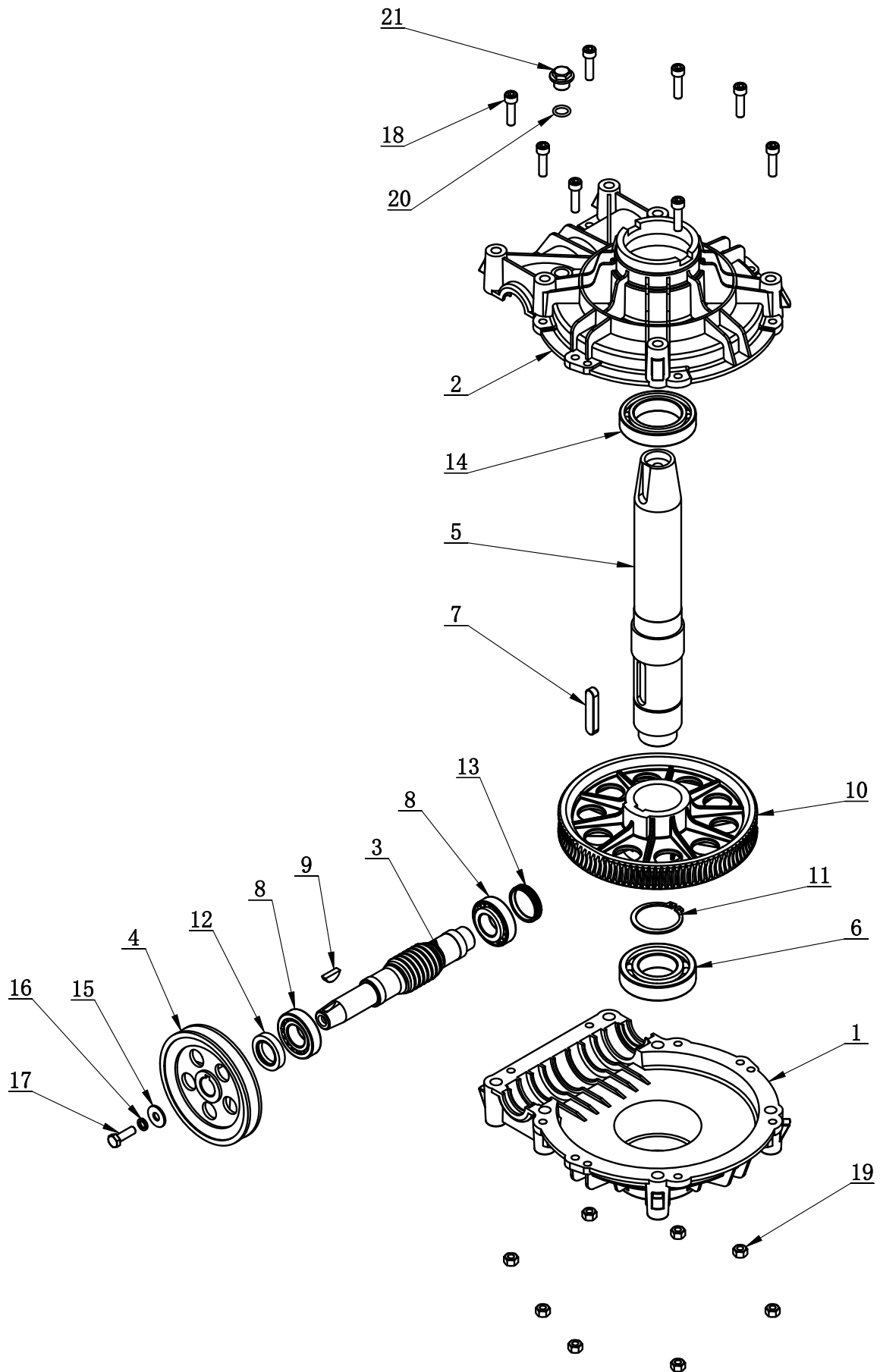



ITEM	PART. No	DESCRIPTION.	QT. Y
1	CT-J-0000005	GEARBOX	1
2	CT-J-0000006	GEARBOX TOP	1
3	CT-J-0000004	WORM ROD	1
4	CT-J-0000008	BELT PULLEY	1
5	CT-J-0000002	WORM SHAFT	1
6	GB276-6208	BEARING	1
7	GB1096-12×8×56	COMMON FLAT KEY	1
8	GB297-30205	BEARING	2
9	GB1099. 1-6×9×22	COMMON SEMI-CIRCULAR KEY	1
10	CT-J-0000003	WORM	1
11	GB894. 1-50	RETAINING RING A-TYPE	1
12	FB25-40 GB13871. 92	SEALED RING	1
13	CT-J-0100000	CAP	1
14	GB276-6010	DEEP GROOVE BALL BEARINGS	1
15	GB96. 2-8	LARGE WASHER C GRADE	1
16	GB93-8	STANDARD SPRING WASHER	1
17	GB5783-M8×25	HEXANGULAR BOLT	1
18	GB70. 1-M8×30	INNER HEXA CYLINDRICAL SCREW	8
19	GB41-M8	HEXANGULAR NUT	8
20	GB3452. 1-13. 2×2. 65-G	HYDRAULIC-PNEUMATIC RUBBER O-RING G TYPE	1
21	TC-10-1400013	BOLT	1

CT-DJ-0334122

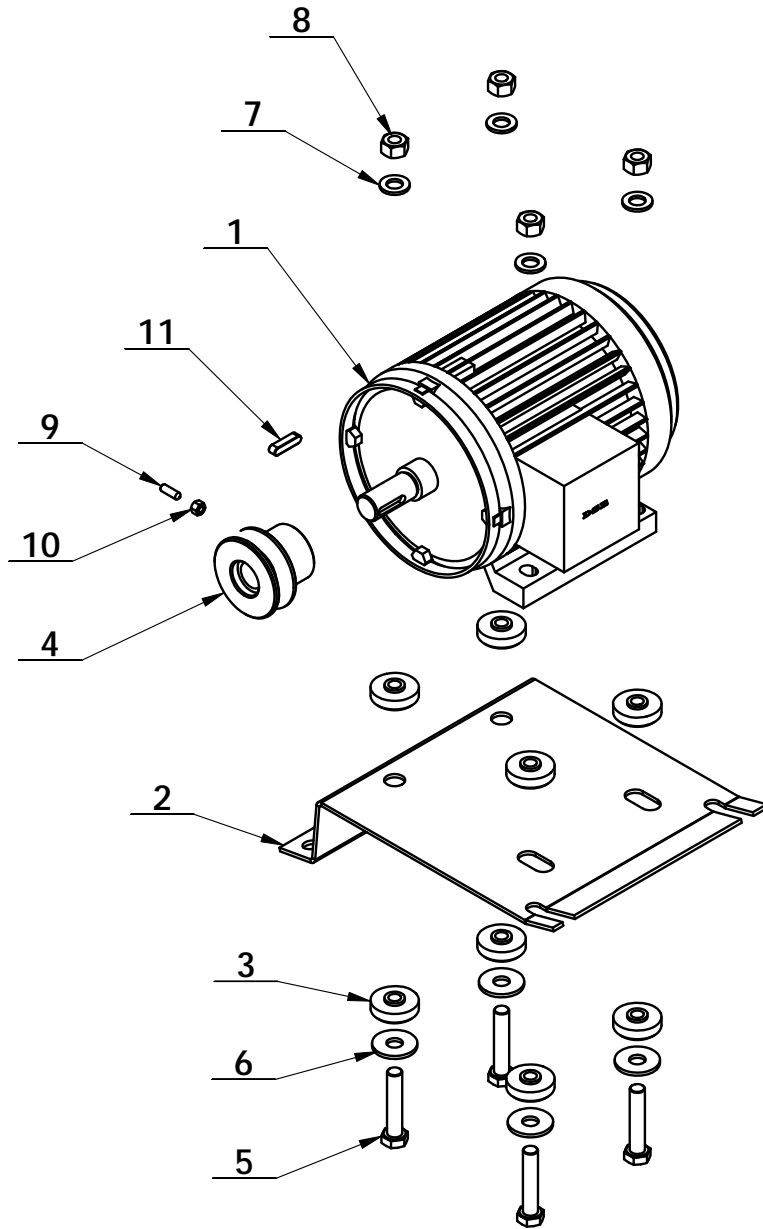

ITEM	PART. No	DESCRIPTION.	QT. Y
1	CT-DJ-0034122	MOTOR (380V, 50Hz, 3P, 0.75KW)	1
2	CT-DJ-0000001	MOTOR SUPPORT	1
3	CT-DJ-0000002	RUBBER WASHER	8
4	CT-DJ-0000004	PULLEY	1
5	GB5783-M10×50	HEXANGULAR BOLT	4
6	GB96. 2-10	LARGE WASHER C GRADE	4
7	GB95-10	FLAT WASHER	4
8	GB41-M10	HEXANGULAR NUT	4
9	GB78-M5×16	INNER HEXA CONIC TERMINUS SET SCREW	1
10	GB41-M5	NUT	1
11	GB1096-6×6×25	COMMON FLAT KEY	1

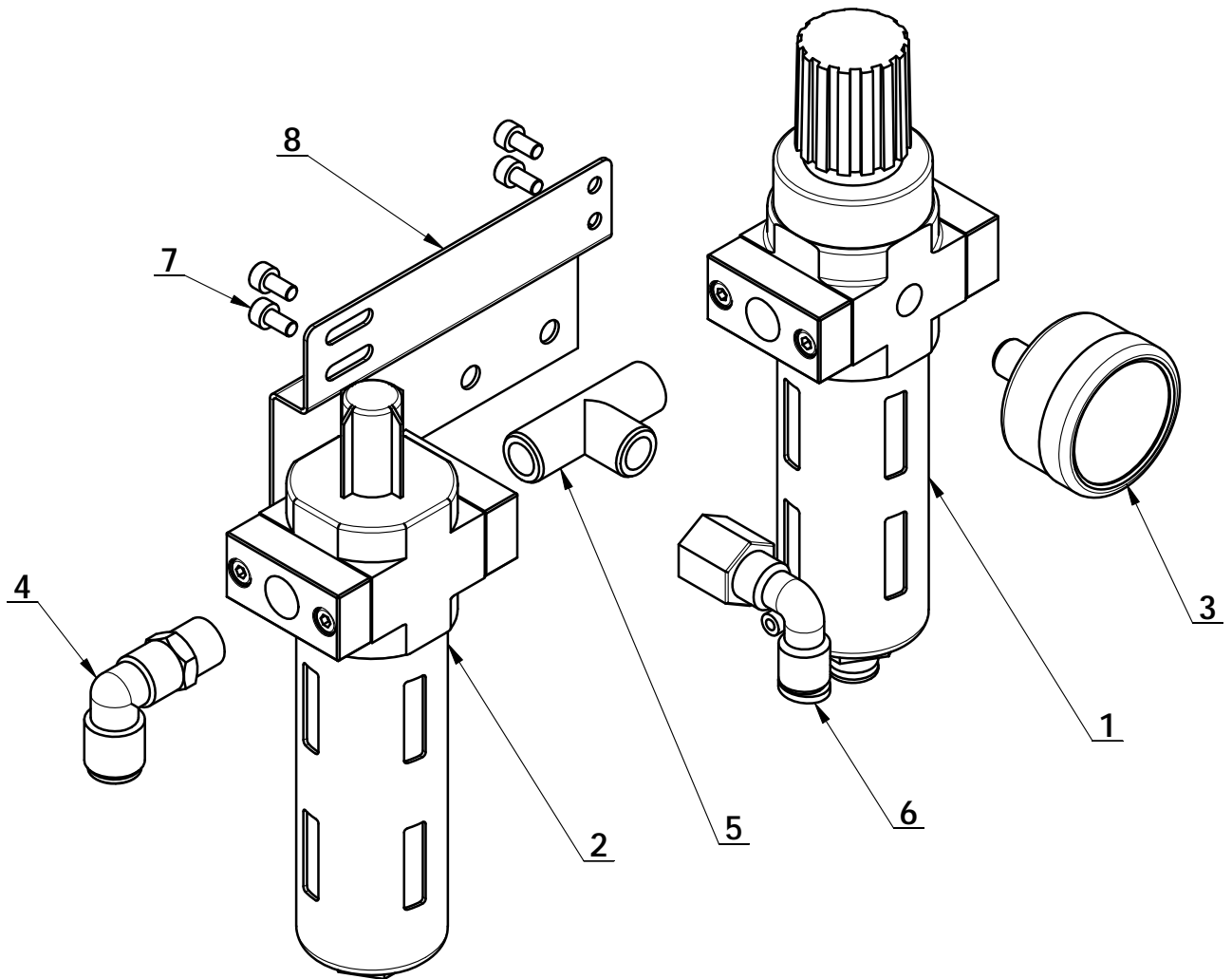

ITEM	PART. No	DESCRIPTION.	QT. Y
1	CT-F-2000010	PRESSURE ADJUST VALVE AND WATER CUP	1
2	CT-F-2000020	OIL CUP	1
3	CT-F-2000003	PRESSURE GAUGE	1
4	FPL 8-02	INSERT ELBOW $\Phi 8$ , R1/4	1
5	PEH 02-02	FEMALE UNION TEE	1
6	FPLF8-02	INSERT ELBOW $\phi 8$ , R1/4	1
7	GB70. 1-M4 $\times$ 8	INNER HEXA CYLINDRICAL SCREW	4
8	CT-F-2000040	AIR REGULATOR BRACKET	1

CT-K-1D00000

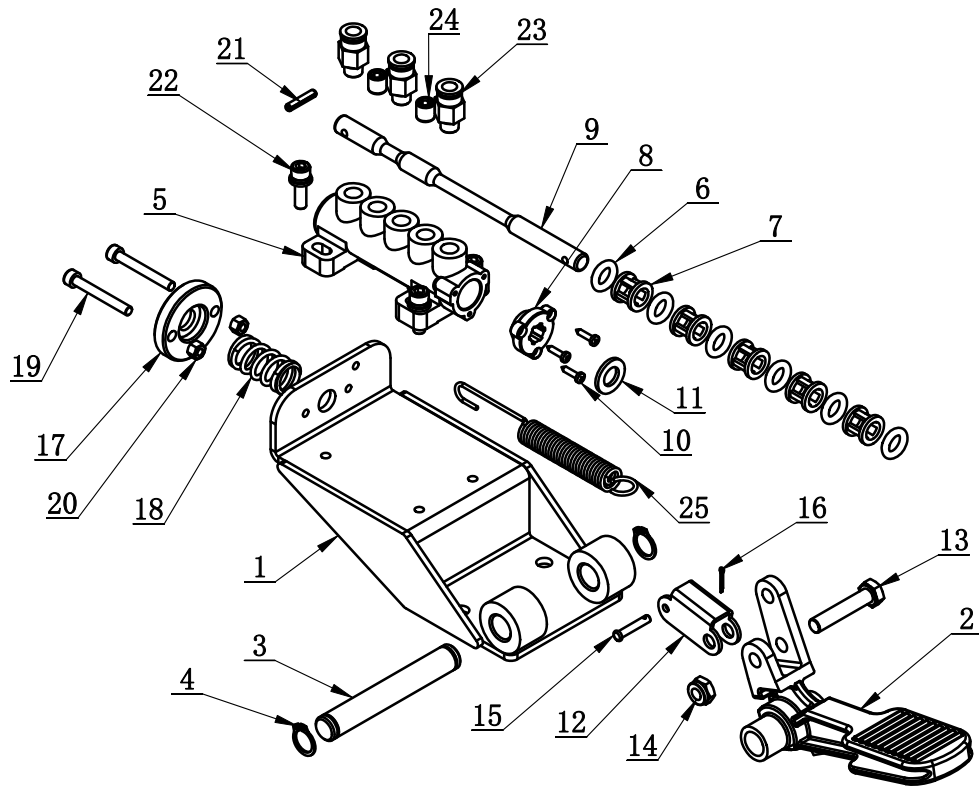

ITEM	PART. No	DESCRIPTION.	QT. Y
1	CT-K-1A10000	PEDAL BRACKET	1
2	CT-D-9100001	PEDAL	1
3	CT-K-1100006	SHAFT	1
4	GB894. 1-14	SHAFT ELATIC BIG RETAINING RING A-TYPE	2
5	CT-D-1110001	VALVE BODY	1
6	CT-K-1100009	O-RING	6
7	CT-D-1110004	SPACER	5
8	CT-D-1110005	VALVE CAP	1
9	CT-K-1A00002	VALVE STEM	1
10	GB845-ST2. 9×13 H C	CROSS PANHEAD TAPPING SCREW	3
11	GB95-10	FLAT WASHER	1
12	CT-D-5100005	CONNECTION PART	1
13	GB5783-M8×40	HEXANGULAR BOLT	1
14	GB889. 1-M8	1-TYPE PREVAILING TORQUE TYPE HEXAGON LOCK NUT	1
15	GB882-4×22	PIN SHAFT	1
16	GB91-1. 6×10	SLOTTED PIN	1
17	CT-K-1100002	MOVABLE PLATE	1
18	CT-K-1100003	SPRING	1
19	GB70. 1-M5×40	INNER HEXA CYLINDRICAL SCREW	2
20	GB41-M5	NUT	2
21	GB879. 1-4×20	PIN	1
22	GB9074-M6×20	COMBINATION SCREW	3
23	FPC 8-01	MALE STRAIGHT	3
24	JB / ZQ4447-1997-G1 / 8×10	SCREWS PLUG G1/8×10	2
25	CT-K-1A00001	SPRING	1

CT-K-3400000

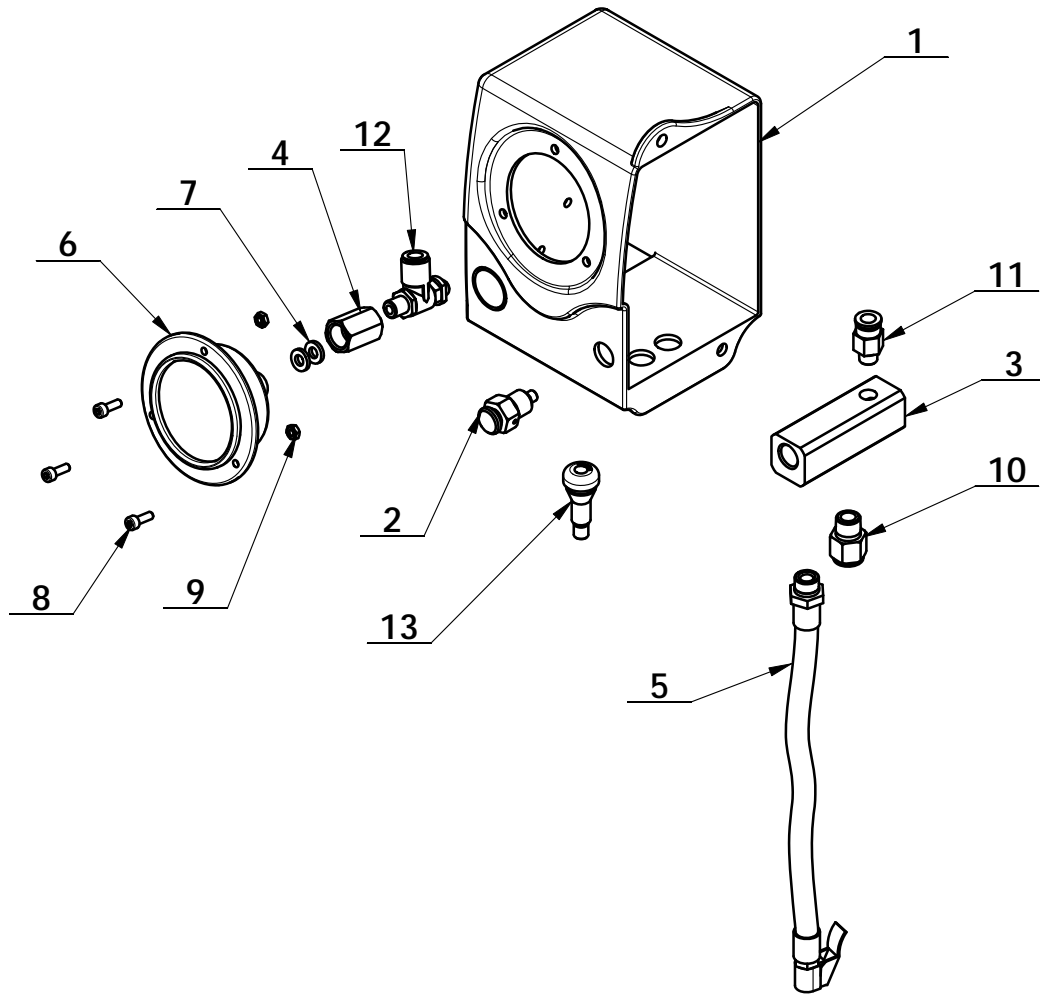

ITEM	PART. No	DESCRIPTION.	QT. Y
1	CT-K-3100001	PRESSURE GAUGE COVER	1
2	CT-K-3110000	EXHAUST VALVE ASSEMBLY	1
3	CT-K-3120000	AIR DISTRIBUTING VALVE	1
4	CT-K-3100002	CONNECT NUT	1
5	CT-K-3100003	INFLATING HOSE	1
6	CT-K-3100004	PRESSURE GAUGE	1
7	TC-10-1620003	AIR REGULATOR WASHER	2
8	GB70.1-M4×12	INNER HEXA CYLINDRICAL SCREW	3
9	GB6170-M4	HEXANGULAR NUT 1-TYPE	3
10	FPC 8-02	MALE STRAIGHT	1
11	FPC 8-01	MALE STRAIGHT	1
12	FJSC-J8-01	ELBOW SPEED CONTROLLER	1
13	CT-K-3100006	AIR VALVE	1

CT-K-4100000

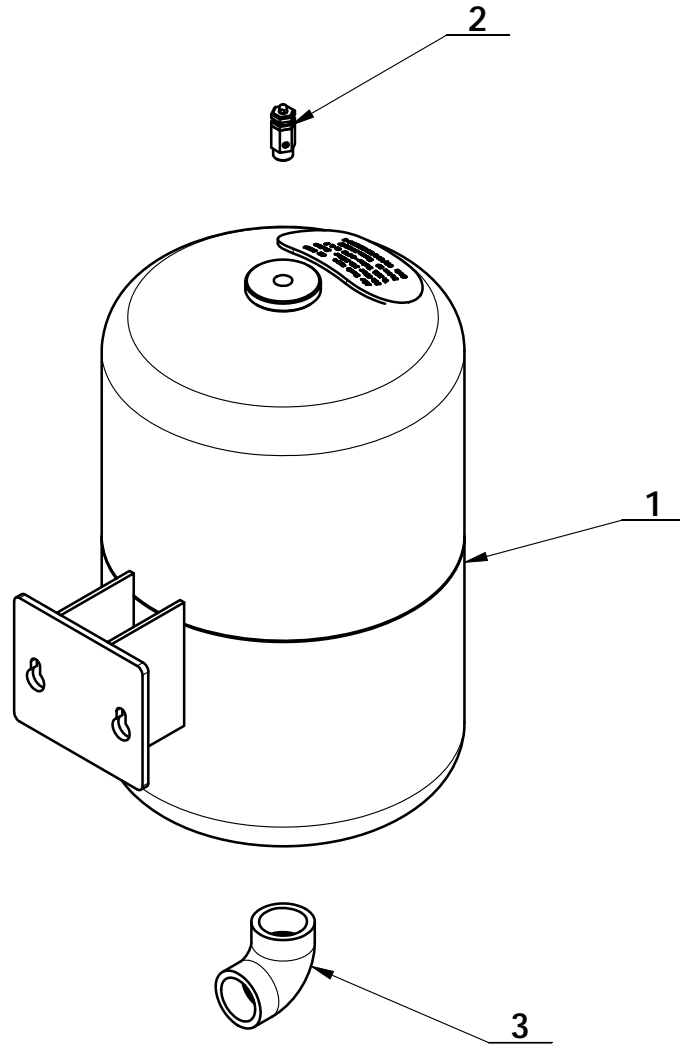

ITEM	PART. No	DESCRIPTION.	QT. Y
1	CT-K-4110000	AIR TANK	1
2	CT-K-4100001	SAFE VALVE	1
3	WT-1-G	ELBOW G1	1

CT-K-2200000

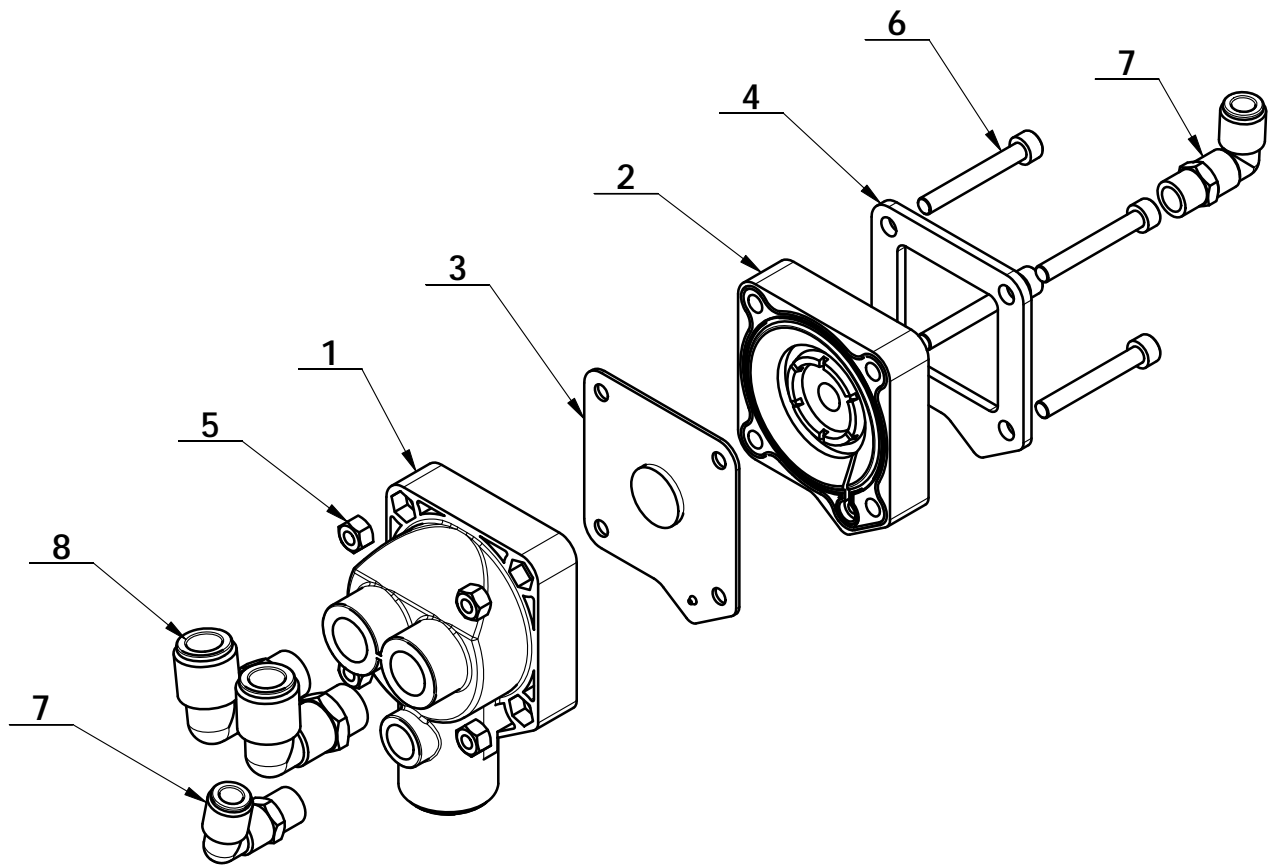

ITEM	PART. No	DESCRIPTION.	QT. Y
1	CT-K-2200002	BOTTOM COVER	1
2	CT-K-2200001	UPPER COVER	1
3	CT-K-2210000	PANEL	1
4	CT-K-2200003	WASHER	1
5	GB41-M6	HEXANGULAR NUT	4
6	GB70. 1-M6×45	INNER HEXA CYLINDRICAL SCREW	4
7	FPL 8-02	INSERT ELBOW Φ8, R1/4	2
8	FPL 12-03	INSERT ELBOW Φ12, R3/8	2

C-80-800000N

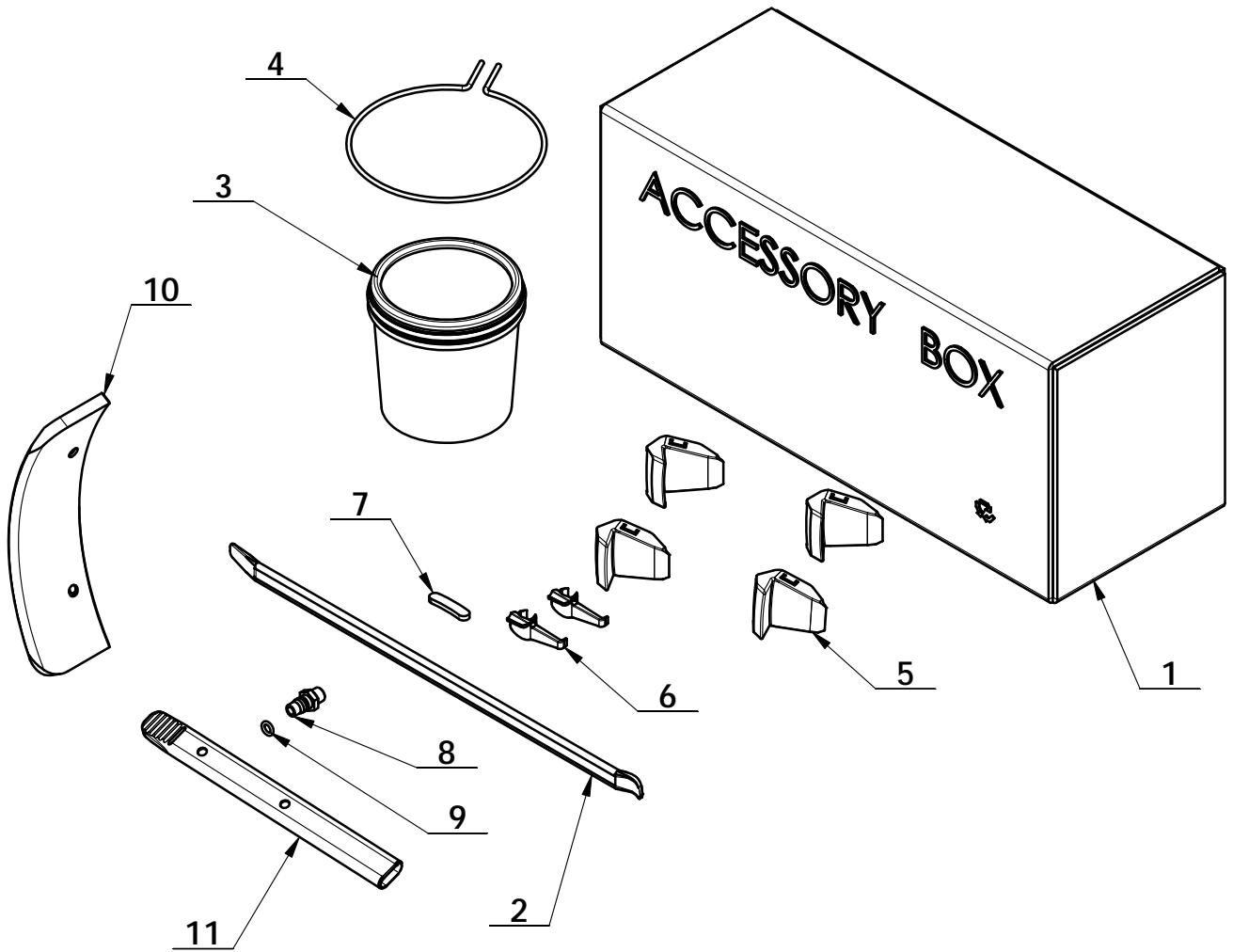

ITEM	PART. No	DESCRIPTION.	QT. Y
1	C-54-8000002	ACCESSORY BOX	1
2	C-54-8000003	20INCH CROWBAR	1
3	C-54-8100000	GREASE CONTAINER	1
4	C-54-8000004	BRACKET	1
5	CT-Y-5000007	CLAMP PROTECTION COVER	4
6	C-54-1300014	SHEATH	2
7	C-54-8000007	TOOL HEAF TAIL WASHER	1
8	C-54-8000011	AIR SUPPLY CONNECTOR	1
9	GB3452.1-8×2.65	HYDRAULIC-PNEUMATIC RUBBER O-RING G TYPE	1
10	C-90-1000013	COVER	1
11	C-54-8000019	CROWBAR JACKET	1